

VICTORIA VESNA & JIM GIMZEWSKI

LOS ANGELES COUNTY MUSEUM OF ART

AT THE INTERSECTION OF ART AND SCIENCE

THINKING

Cover image: The nano logo was designed by Victoria Vesna's team based on discussions with Jim Gimzewski about the way molecules can be purposefully repositioned using the tip of the Scanning Tunneling Microscope (STM). Gimzewski contacted his colleague and friend, Don Eigler, first person to move individual xenon atoms to form an IBM logo twelve years ago. Don agreed to create the nano logo that pays homage to this revolutionary move into manipulation of molecules. Eigler gave the task to Kelly McGroddy who worked in his lab to create the 'nano' design really on the nanoscale using carbon monoxide molecules. This seemed particularly appropriate for the Los Angeles context.

CREATING

EXHIBITING

# NANO

NANO IS A COLLABORATION BETWEEN MEDIA ARTIST VICTORIA VESNA AND NANO SCIENTIST JIM GIMZEWSKI. TOGETHER THEY ASSEMBLED A PROJECT TEAM OF THEIR STUDENTS AT THE UCLA DEPARTMENTS OF DESIGN|MEDIA ARTS AND CHEMISTRY, LED BY A RECENT GRADUATE OF DESIGN|MEDIA ARTS, ASHOK SUKUMARAN. THEY WORKED WITH THE ARCHITECTURAL OFFICE OF JOHNSTON MARKLEE AND ASSOCIATES TO CREATE A LARGE EXPERIENTIAL INTERACTIVE WORK THAT CONSISTS OF A SERIES OF INTERCONNECTED INSTALLATIONS. PROFESSOR N. KATHERINE HAYLES (DEPARTMENT OF ENGLISH), ALSO WITH GRADUATE STUDENTS, DEVELOPED THE TEXT COMPONENT WITHIN THE GALLERY. WORKING CLOSELY WITH THE DIRECTOR OF THE BOONE CHILDREN'S MUSEUM, ROBERT SAIN, AND THE CURATOR OF THE CONTEMPORARY ART AT LACMA, CAROL EILEL, THESE EXHIBITS WERE CONNECTED TO THE CONTEXT OF THE MUSEUM AND THE PARTICULAR AUDIENCE THIS EXPERIMENTAL SPACE ATTRACTS.

## CONTENTS:

INTRODUCTION PAGE 05

GENESIS PAGE 09

ARCHITECTURE PAGE 15

INSTALLATIONS PAGE 37

ACTIVITIES AND EVENTS PAGE 71

PEOPLE PAGE 78

## AT THE INTERSECTION OF ART AND SCIENCE: NANO

In both the philosophical and visual sense, **SEEING IS BELIEVING** does not apply to nanotechnology, for there is nothing even remotely visible to create proof of existence. On the atomic and molecular scale, data is recorded by sensing and probing in a very abstract manner, which requires complex and approximate interpretations. More than in any other science, visualization and creation of a narrative becomes necessary to describe what is sensed, not seen. Nevertheless, many of the images generated in science and popular culture are not related to data at all, but come from visualizations and animations frequently inspired or created directly from science fiction. Likewise, much of this imagery is based on industrial models and is very mechanistic in nature, even though nanotechnology research is at a scale where cogs, gears, cables, levers and assembly lines as functional components appear to be highly unlikely. Nano is conceived to offer an alternative way of **SEEING** the molecular world by immersing the audience in the environment that is designed to raise awareness of ourselves as molecular beings.

## INTRODUCTION

Scientists have tried to explain this disparity by comparing the nanometer to the thickness of a human hair: the average thickness of a human hair is  $\sim 5 \times 10^{-5} \text{m}$ , which is (50,000) nm. Or, the little fingernail: around 1 cm across, which is equal ten million nanometers. Recently, Nobel Laureate Sir Harry Kroto described the nanometer by comparing the size of a human head to that of the planet earth. A nanometer would be the size of a human head in relation to the size of the planet if the planet were the size of the human head.

But, even that is difficult to intuitively grasp or visualize. What type of perceptual shift in our minds has to take place to comprehend the work that nano science is attempting and what would be the repercussions of such a shift? And, how does working on this level influence the way scientists think who engage this work? In order to address this we put together a team of media artists, nanoscientists and humanists need to join forces and envision such possibilities.

Although nanotechnology is used widely to refer to something very tiny, this new science will eventually revolutionize and impact every single aspect of our lives. It will do this on all scales all the way up from the atom to the planet earth and beyond. The very modus operandi of science is already changing under its influence. Nanoscience not only requires input from practically every scientific discipline, but it also

needs direct and intense collaboration with the humanities and the arts. It is highly probable that this new technology will turn the world, as we know it, upside down, from the bottom up. Scientists progressively turned up the magnification, but no matter how good the glass lenses were, how precise the brass tubes and screws were, at around  $\times 10,000$ , the image goes fuzzier until, at  $\times 100,000$ , the image is basically blank. This is called **THE RALEIGH LIMIT**, which says you cannot see anything with using a wave that is smaller than half the size of the wave. In other words, this light wave has a size just like an ocean wave has the distance between its crests. The length of the wave is the feature that limits what we **SEE** which has a limit when we use regular light of two hundred nanometers. It is already twice the size of a wire in a Pentium IV, or a few hundred times thinner than a hair - it is back to the metric. To get higher magnification, scientists used shorter waves and even the wave properties of electrons. Nevertheless, despite the progress, the high energies and conditions required to make these higher resolution images started to destroy the very objects they wanted to **SEE**. In effect, they ended up looking at matter using something like a focused blowtorch in a vacuum.

Necessity as the mother of invention promulgated the researchers to build a machine where the little needle could be moved across the surface of the oxide film and thereby seek out the

# INTRODUCTION

pinholes. Thinking about how the new invention worked, led to an important realization scribbled on a lab book. By using electron tunneling as a probe, they realized that mainly the last atom on the needle (the closest on the surface) really sensed the local properties. The needle moving across the surface created a topographic representation, and a few back-of-the-envelope calculations indicated even single atoms could be resolved. What they realized was a major paradigm shift - rather than using lenses and waves, they were recording by feeling. By 2003, a whole range of microscopes based on tactile sensing had been developed, and many companies were established to manufacture machines that are used by microelectronics and data storage industries.

We should take a closer look at ourselves as magnificent nano-beings, connected and part of an entire living body of this Earth and beyond for inspiration, not to machines of the past. DNA, proteins, and cells of all sorts already function at nano-scale in animals and plants, and they work at normal temperatures. The nano exhibition is inspired by work of Buckminster Fuller who early on recognized that patterns in nature offer a solution to design problems of humanity. Until 1985, we were only aware of two carbon molecules - graphite and diamond. The third was buckminsterfullerene because it so resembled the architectural structure of Expo 67. Thus, from the very discovery of the third carbon molecule, that has become the icon of nanotechnology, science and culture are linked.

Both nanotechnology and media arts, by their very nature, have a common ground in addressing the issues of manipulation, particularly sensory perception, questioning our reaction, changing the way we think. They are complementary, and the issues that are raised start to spill over into fundamental problems of the limits of psychology, anthropology, biology and so on. It is as if the doors of perception have suddenly opened and the microscope's imperfection of truly representing object form forces us to question our traditional (Western) values of reality.

As common technologies are being used in arts, sciences and practically all disciplines, borders are becoming increasingly indiscernible, and we have to be more conscious than ever of the metaphors being generated. The barriers between disciplines and people in them are more or less psychological. Currently, the vast majority of stories and imagery being circulated in the public realm are based on 20th century thinking that is largely centered on machines. Nanoscale science and media art are powerful synergies that can promulgate the 21st century emergence of a new 3rd culture, embracing biologically inspired shifts, new aesthetics and definitions. Nano is meant to be a first step in creating a space where asking questions is part of the experience rather than being told the 'facts'. At this stage, imagination is needed to envision the future use of this new science and everyone is invited to participate.

Victoria Vesna and Jim Gimzewski

NANO IS A DIFFERENT KIND OF EXHIBITION:

IT IS NOT LINEAR OR CHRONOLOGICAL

THERE IS NO BEGINNING OR END

THERE IS NO RIGHT WAY OR WRONG WAY TO GO THROUGH IT

IT IS NOT ABOUT IMPARTING INFORMATION

IT IS ABOUT YOUR OWN EXPERIENCE

IT IS DESIGNED TO BLUR BOUNDARIES

IT IS A NEW KIND OF STUDIO, CULTURAL LABORATORY,

AND SOCIAL INTERACTION SPACE

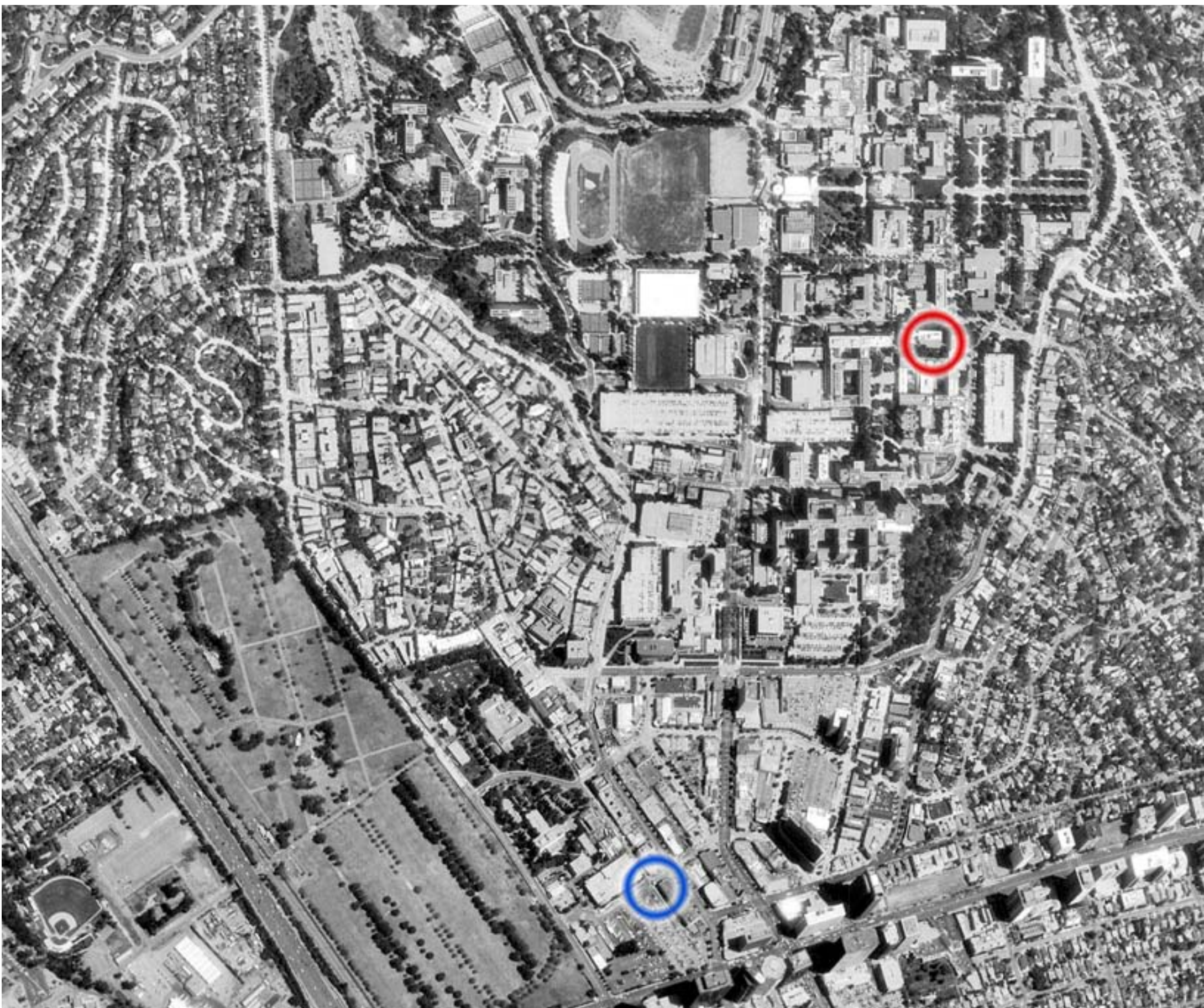

Departments of Chemistry (red) and Design|Media Arts (blue).

# GENESIS

NANO emerged from a process that included artists, chemists, nanoscientists, writers, theoreticians, musicians, monks, architects, engineers, programmers and poets.

Their transdisciplinarity has worked through not only the sharing of ideas, but often through the sharing of physical spaces, and presence in each others labs and work spaces.



TENZIN WANGCHUK, Design | Media Arts student, recording cell sounds at the Pico Lab. Tenzin was on the audio team together with Design | Media Arts graduate student ANNE NIEMETZ, and doctoral student in chemistry, ANDREW PELLING.

DANIEL SAUTER, Design | Media Arts graduate student, in the Sense Lab developing robotic balls for the central cell space.

VICTORIA VESNA and PETE CONOLLY (designer of the large kaleidoscope), being introduced to the workings of the Scanning Tunneling Microscope in the Pico Lab by JIM GIMZEWSKI, accompanied by doctoral students ANDREW PELLING and KATHY SKIBO.

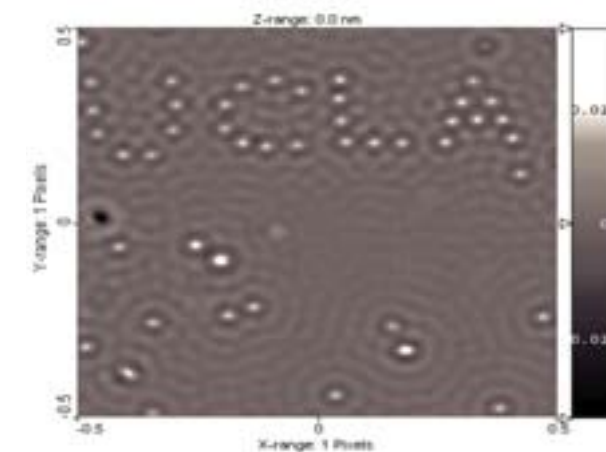

STM-image (also see cover image).

THE SCANNING TUNNELING MICROSCOPE was developed in the mid eighties and created a new paradigm shift in microscopy which radically transformed the way scientists fundamentally viewed molecular and atoms. The microscope uses the apex of a tiny needle to literally feel the shape of atoms and molecules on surfaces using tactile sensing. The sensing is provided through quantum tunneling. The transformation that occurred was between seeing as through using the wave properties of light or electrons tot touching. This extension of the human finger shrunk some 10 million times enables also the manipulation of atoms and molecules. Such a direct intimate connection to the atom world was not even foreseen by the Quantum physicists at the turn of the 19th century. In fact ERWIN SCHRÖDINGER wrote that mankind would never experiment with one atom or electron. The STM changed this perception and together with the discovery a new form of carbon, bucky balls, inspired the new vision and dreams of nano-technology that accompanied the birth of the 21st century.

# GENESIS

"THE FURTHER ART ADVANCES THE CLOSER IT APPROACHES SCIENCE, THE FURTHER SCIENCE ADVANCES THE CLOSER IT APPROACHES ART."

R. BUCKMINSTER FULLER, UTOPIA TO OBLIVION, 1938.



ASHOK SUKUMARAN, Design | Media Arts graduate, working on the central cell with ADAM STEIG, chemistry student majoring in Nanoscience. Ashok was the project director responsible for keeping track of the complex conceptual and technical aspects of Nano.



ANNE NIEMETZ, ANDREW PELLING, and OSMAN KHAN testing a possible projection material in Victoria's Lab.

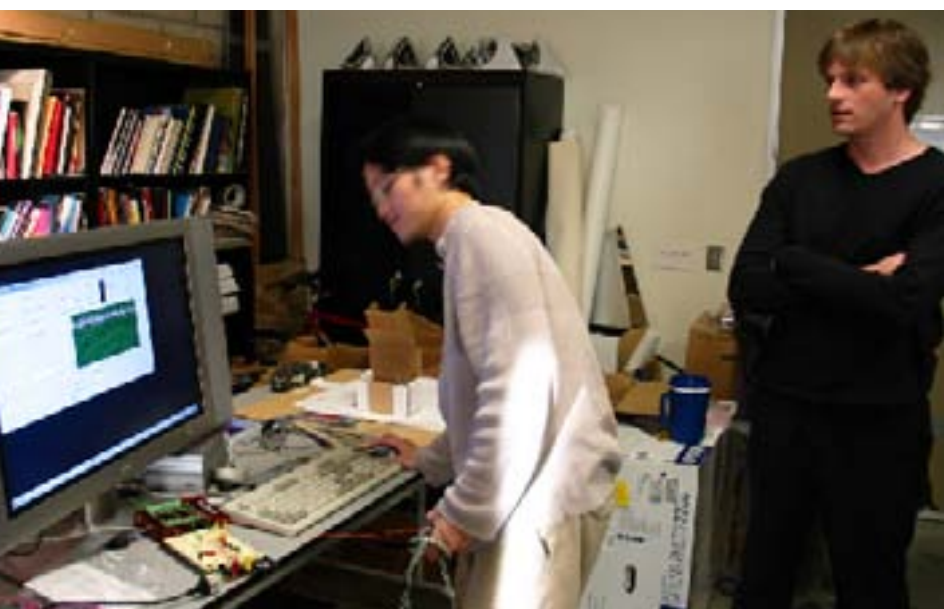

SEAN CROWE, mathematician and programmer, working with engineering student LUKE LEE on connecting the software and hardware.



Johnston Marklee & Associates are an architectural practice based in Los Angeles, California. The principals, Sharon Johnston and Mark Lee, are both faculty at the UCLA Department of Architecture.

The architects were presented with the challenge of not approaching the exhibition space as a container, but more a sculptural structure that blended in with the installations and connected directly to the conceptual framework.



The architectural model at Johnston Marklee Studio. Principals SHARON JOHNSTON and MARK LEE with LACMA West director BOB SAIN, his associate KELLY CARNEY, and VICTORIA VESNA.



May's Landing, Point Dume, Malibu.



Tibetan monks engage in a lively discussion about the molecular realm.

# GENESIS



Viewing nano images on a window projection.



Nanoscientists return from catching the wave.



During the year-long development of Nano, monthly retreats were held at May's landing in Malibu. Here everyone on the team had an opportunity not only to discuss the concept and production, but also to learn more about each other on a human level. These 'nonproductive' times were perhaps most important in developing the close collaborative atmosphere necessary for the project's success. During the production, many outside of the group were also invited to the retreats to give feedback and discuss the project concepts.

The monthly retreats on the beach provided a space where friendship developed between people from very different disciplines and in this way the language and methodology boundaries were bridged successfully.

Creativity, imagination and perception are essential in the development of a new methodology necessary for the emerging fields of both nano-science and media arts. Graduate students in the team from both disciplines gained an enormous edge

by learning how to cross boundaries and expand their viewpoints. The intersection of art and science has promulgated the emergence of a third culture, a hybrid of art and science, the known and unknown which has had a powerful impact on the research approaches taken by nano science and media art graduate students. In particular there articulation, awareness and imagination were shifted.

# ARCHITECTURE

THE ARCHITECTURE OF NANO ENGAGES THE EXHIBITIONS' MEDIA INSTALLATIONS WITH SITE-SPECIFIC FORMS, APERTURES, AND SURFACES TO OPTIMIZE THE DISPLAY OF AND INTERACTION WITH THE EXPERIMENTAL PROJECTIONS. USING SHAPES INFORMED BY BOTH BUCKMINSTER FULLER'S DYMAXION WORLD MAP AND MOLECULAR NANOSTRUCTURES, THE FOLDED THREE-DIMENSIONAL SURFACES OF NANO'S ARCHITECTURE CREATE INTERLOCKING LAYERS OF ENCLOSED AND SEMI-ENCLOSED CELLS AND SENSE SPACES. THE ARCHITECTURAL STRUCTURES, REFLECTING MOLECULAR PATTERNS, ACT AS THRESHOLDS TO TRANSPOSE THE VISITORS' EXPERIENCE FROM THE HUMAN SCALE TO THE NANO SCALE.

Johnston Marklee & Associates. **principals:** Sharon Johnston and Mark Lee.

**project architect:** Anne Rosenberg. **project team:** Jeff Adams, Diego Arraigada, Lars Holt, Daveed Kapoor, Anton Schneider.

## CONDITIONS

It was important for the artists and scientists who work in the academic environment to figure out a way to relate some of their research in a wider cultural arena. LACMA West provided the perfect location and environment for this kind of experimental exhibition.

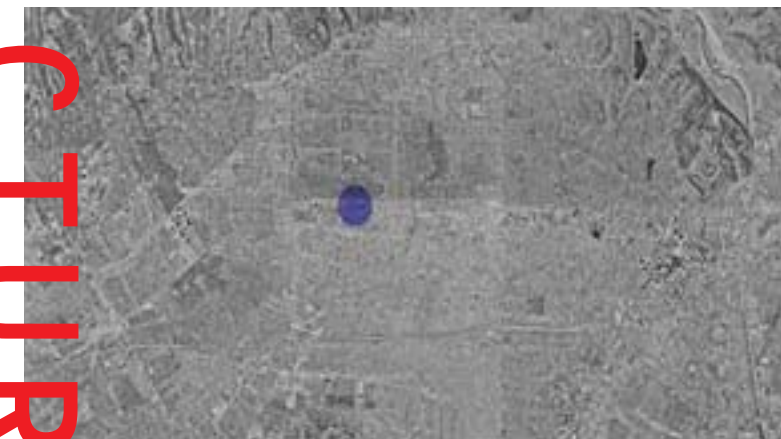

Los Angeles 1:100000



Miracle Mile 1:10000



LACMA Campus 1:1000



The architecture of the exhibition mediates between the interior space of the Boone Children's Gallery and the experiential environment created by the media installations.



LACMA west 1:500

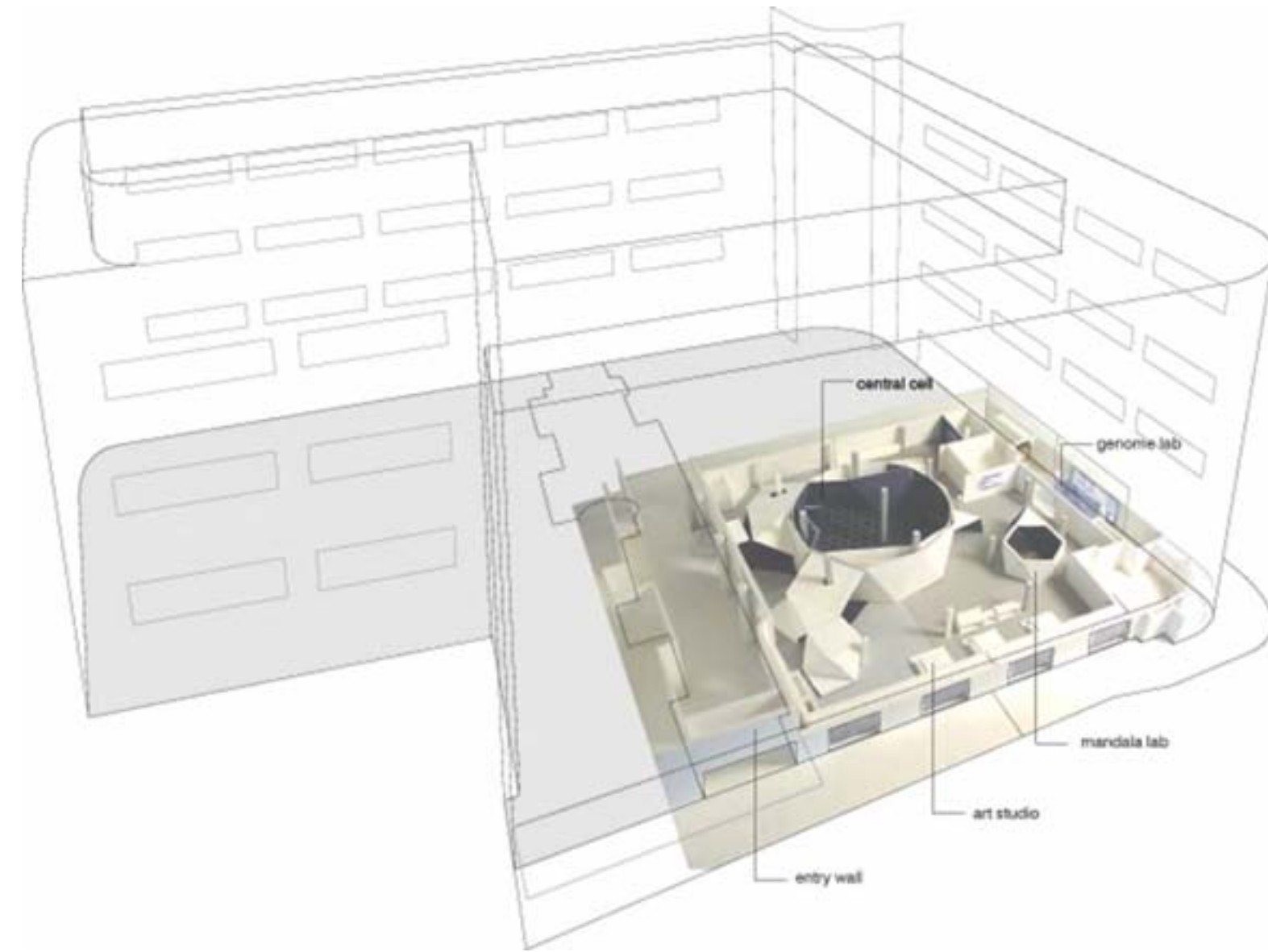

ARCHITECTURE

EXHIBITION



Conceived by media artist Victoria Vesna and nano scientist Jim Gimzewski, the participatory multimedia installations are based on the manipulation of individual molecules projected at a monumental scale, aiming to shift ones perception of reality from a visual culture to one based on sensing and connectivity.

Zero@wavefunction interactive installation:

- A. Projector
- B. Interacting Person
- C. Shadow
- D. Projected Image

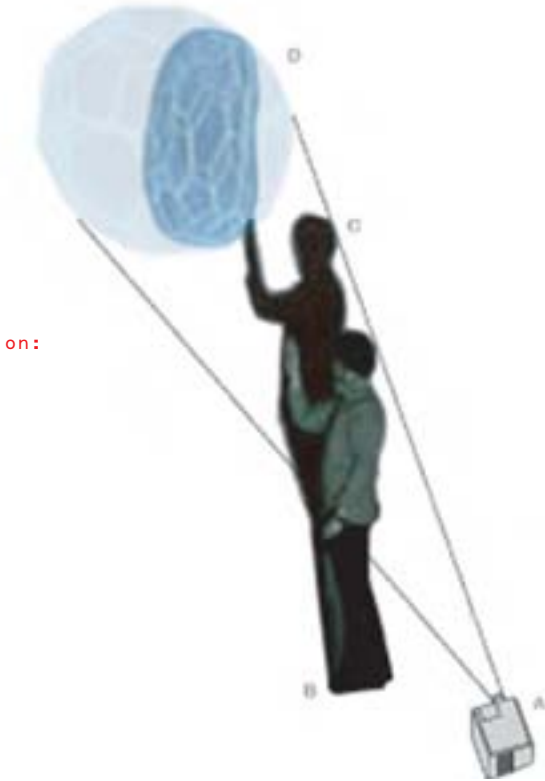

# ARCHITECTURE

From Architecture to Science: Buckminsterfullerene - a spherical cage molecule of carbohydrate discovered via Fuller's Expo Dome of 1967.

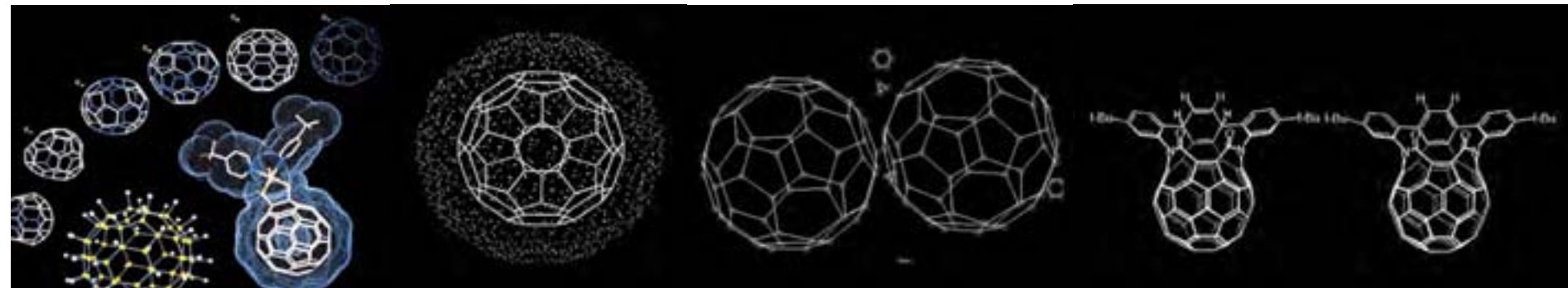

C44, C50, C54, C60, C70 Buckybabies. C60 Buckminster-fullerene. Bucky Ball Molecules. Ring-Open C60 Derivatives.

Nano - Greek for dwarf- is concerned with the control of microscopic matter at the scale of individual atoms and molecules. nano = 10<sup>-9</sup>.

Rather than forming a backdrop for art in a traditional exhibition, the architecture of nano actively forms a synergy with the exhibition media and the gallery visitor.

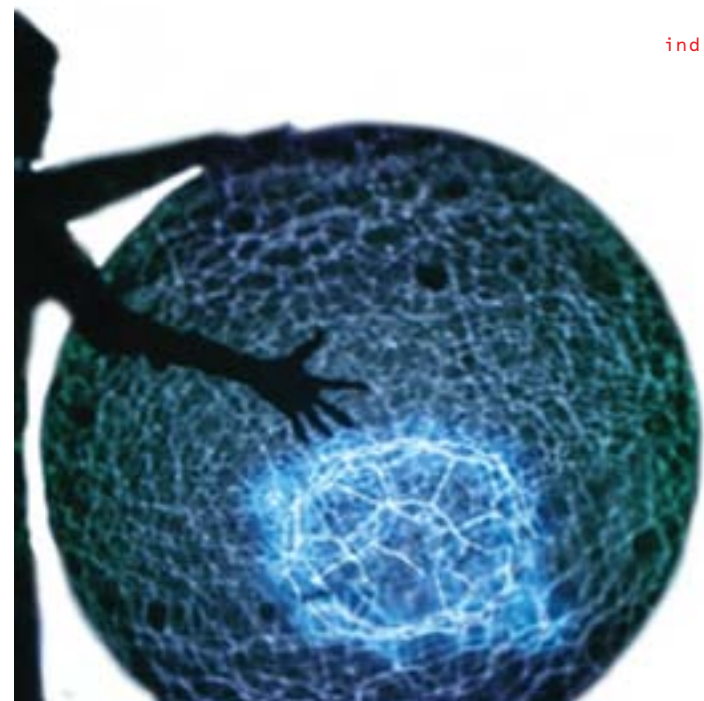

## PLANNING



Russian Dolls: Environment nested within environment.

The planning results from 2 programmatically driven demands:

- 1) control accessibility and direct circulation flows
- 2) conceal structure and mechanical areas



Koumoutsakos and Leonard, evolution of vorticity formation in the flow around an impulsively started circular cylinder, 1995.



Centered on a double-walled cylindrical space, the inner and outer walls freely adjust to accommodate program.

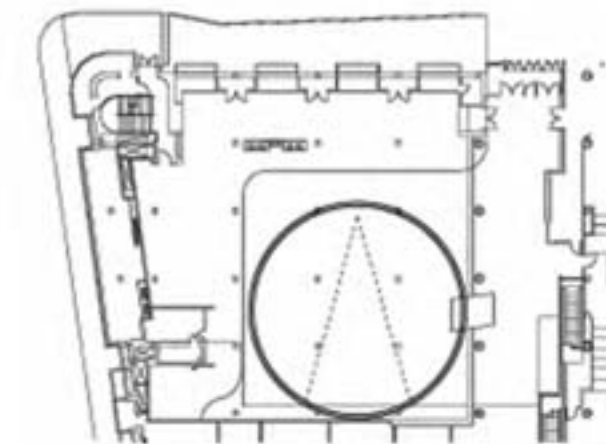

1. Central Cell begins as a primitive sphere scaled for the zero-wavefunction projection.

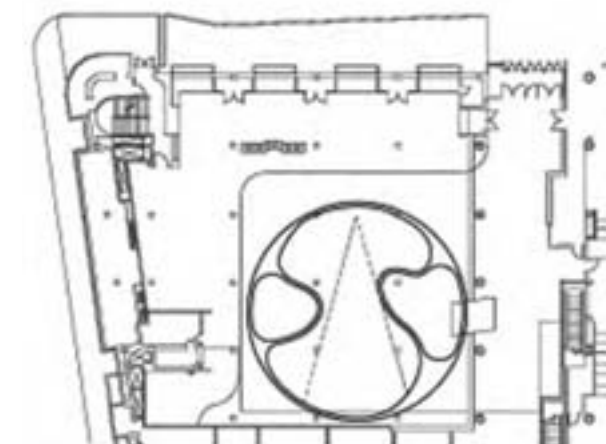

2. Pockets develop within the central cell creating additional space for installations.

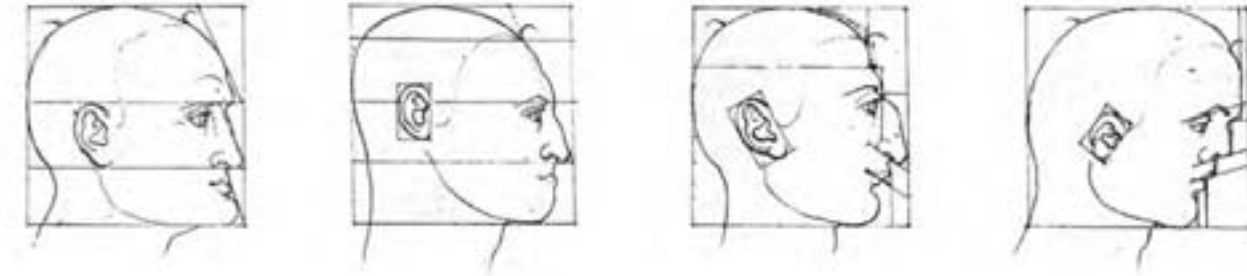

Albrecht Durer, *Constructed Heads, Studies in Physiognomy*, c. 1526-27.

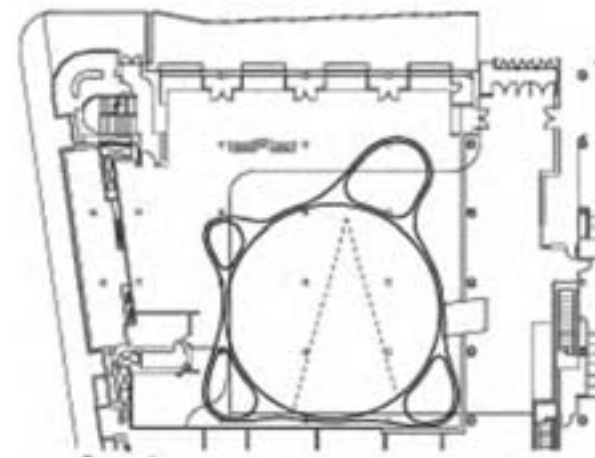

3. External cells attach in a viral configuration.

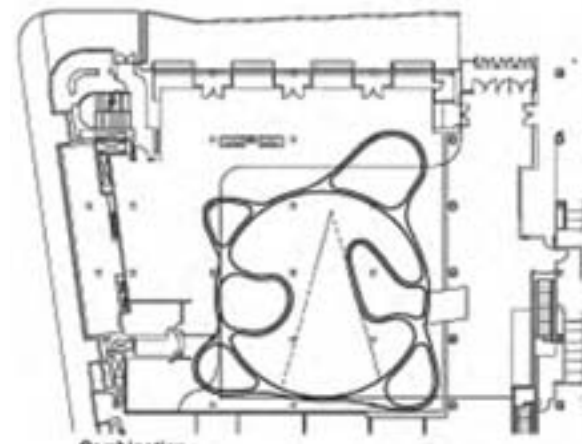

4. Combination.

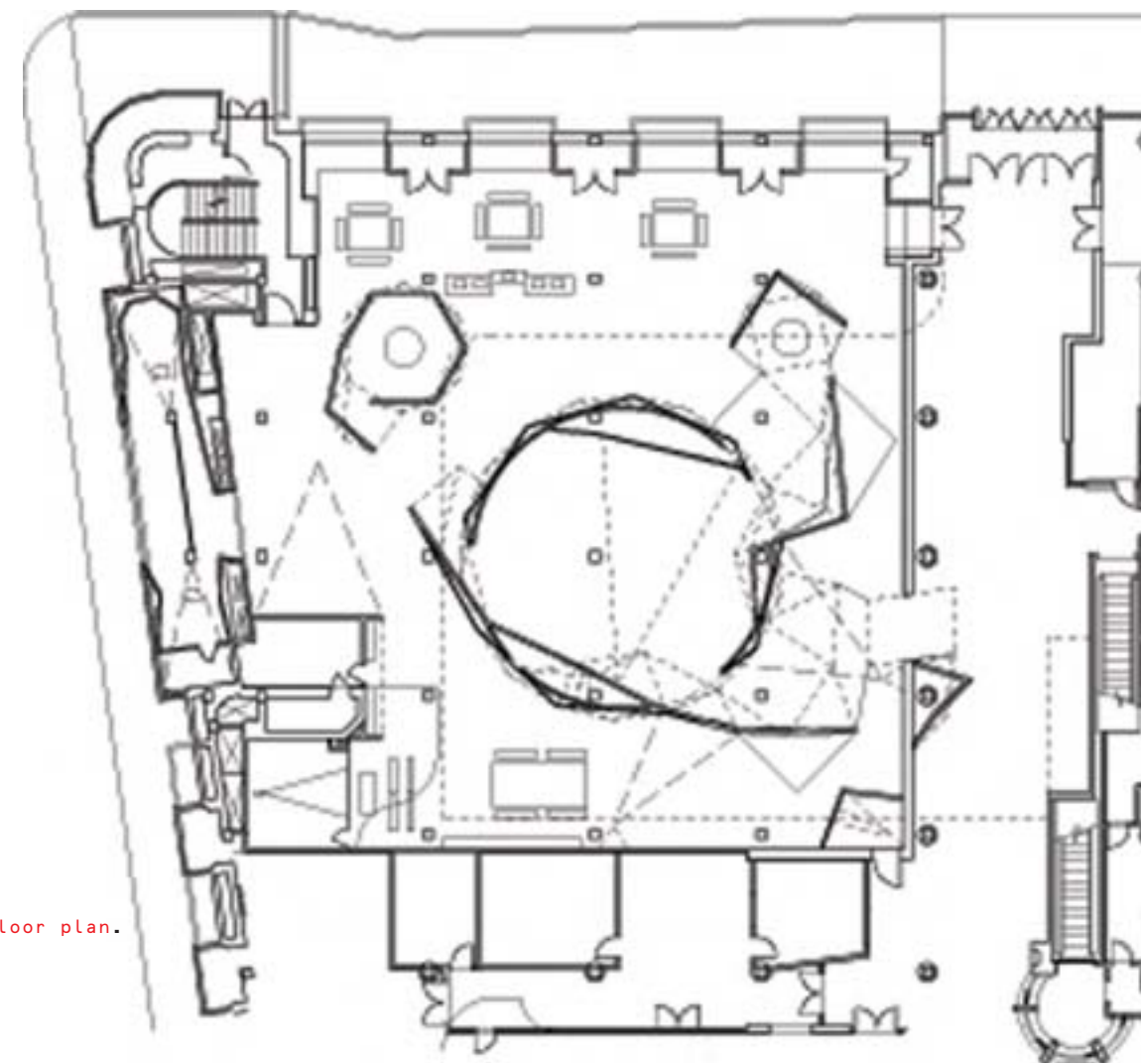

Nano floor plan.

- 1. Entry
- 2. Central Cell
- 3. Atomic Manipulation Lab
- 4. Mandala Lab
- 5. Genome Lab
- 6. Resource
- 7. Projection Theater
- 8. Art Studio
- 9. Sense Space

# ARCHITECTURE

## SURFACE AND SCALE

The strategies for surface articulation address dynamic modes of tactility, scale, structure, and techniques of assembly inherent in the exhibition.

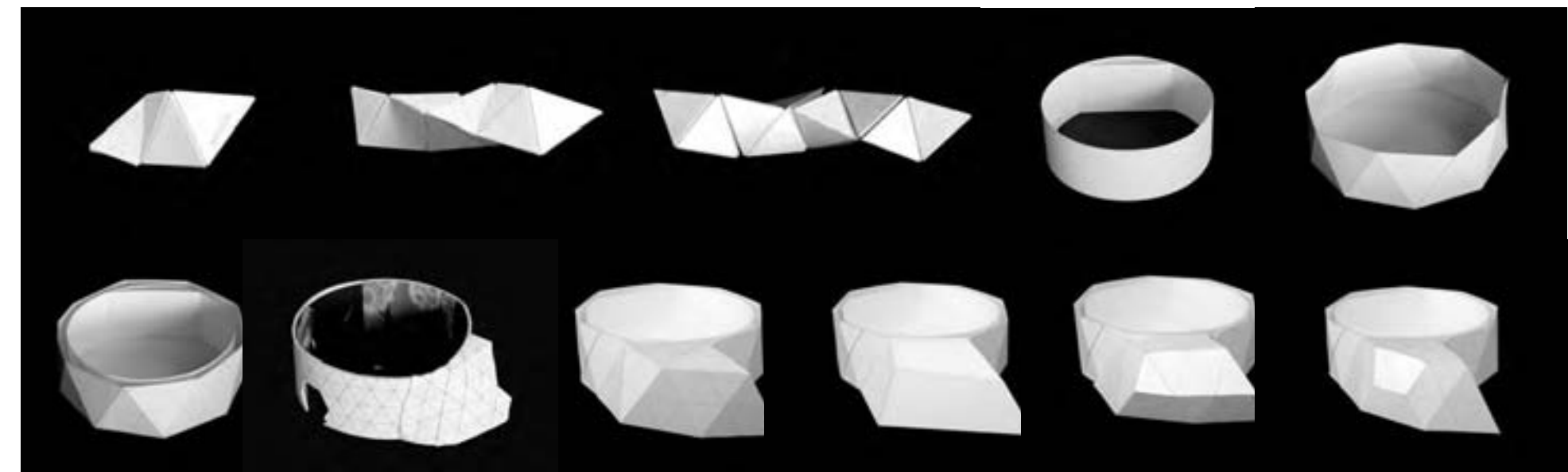

Tetrahex, Decahedron, Bifurcation studies.

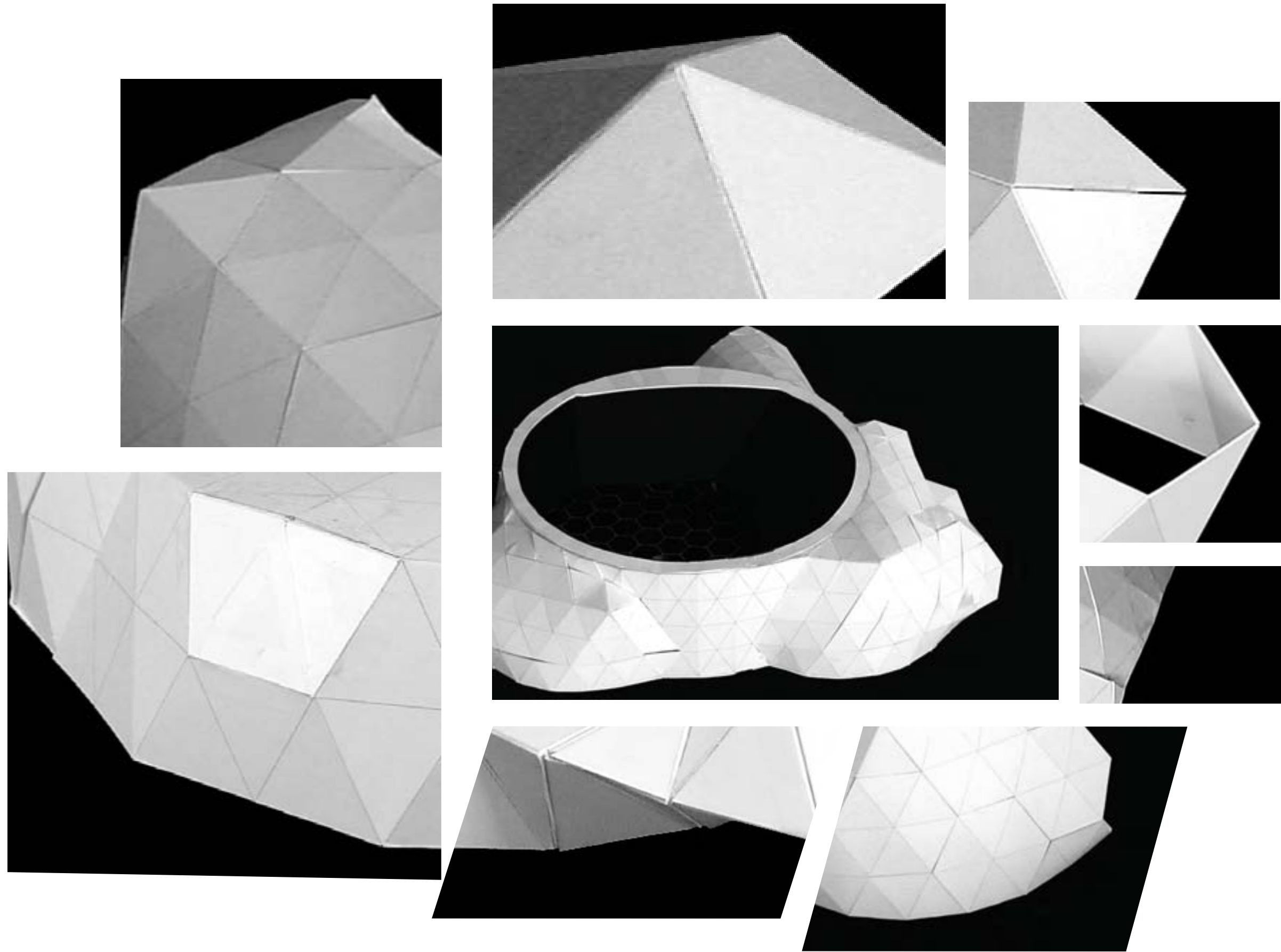

# ARCHITECTURE

## SPHERICAL GEOMETRY

The fusion of primitive spheres with the pure circle of the central cell generates the starting point for opening up the central cell and creating a connection between the cell and the gallery.



John Utzon, Sydney Opera House, 1969.

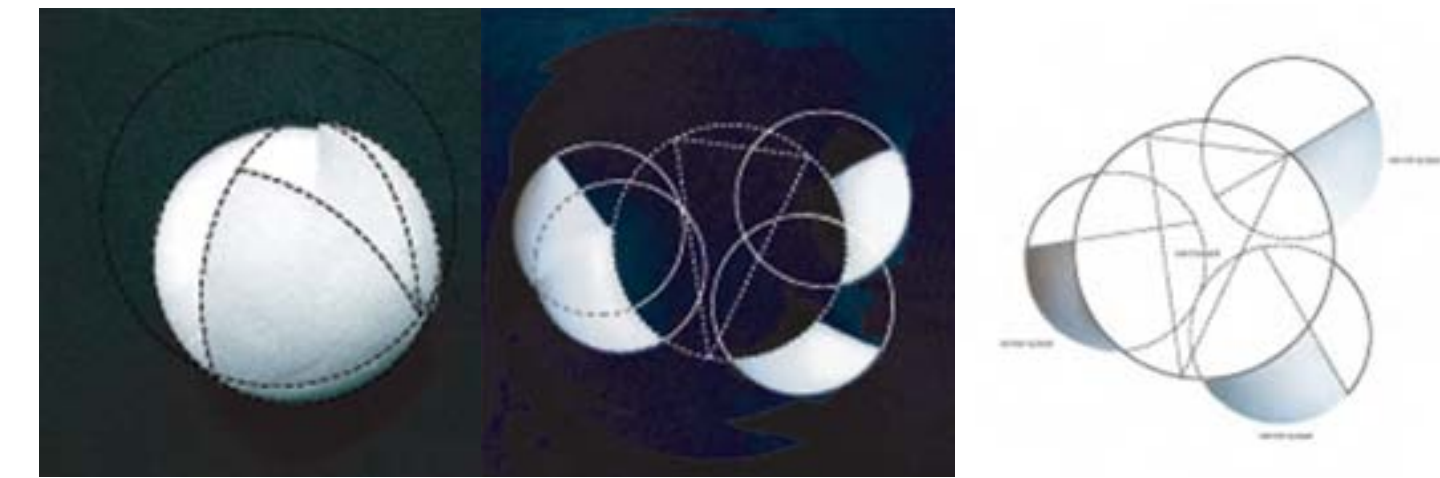



LEFT TO RIGHT: Buckminster Fuller, Geoscope, 1952. Buckminster Fuller, Geometrical techniques for tessellating spheres.

Geometric configurations inherent on the tessellated skins of spheres produce opportunity for splicing and manipulating solids to create spaces for circulation, projection, and sensory installation.

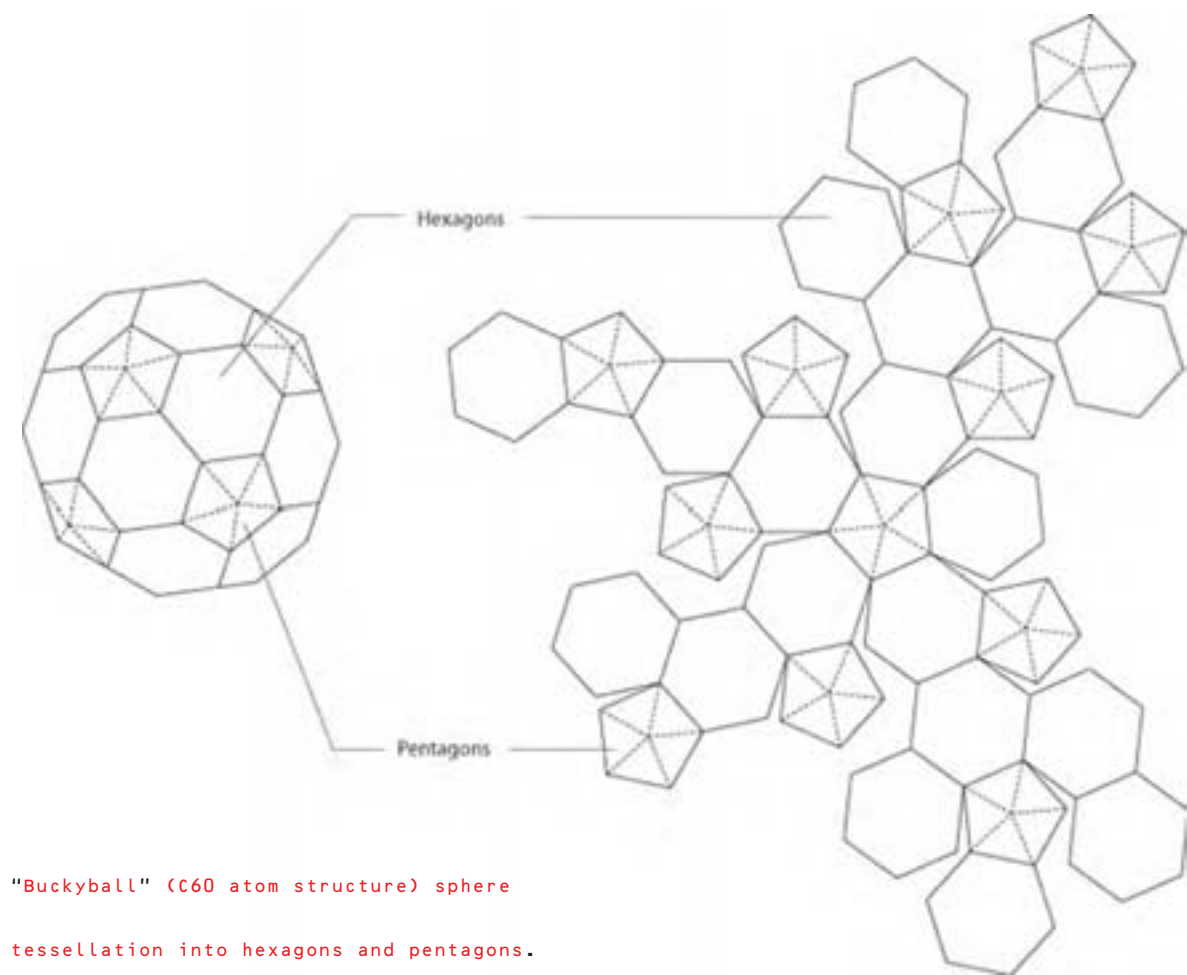
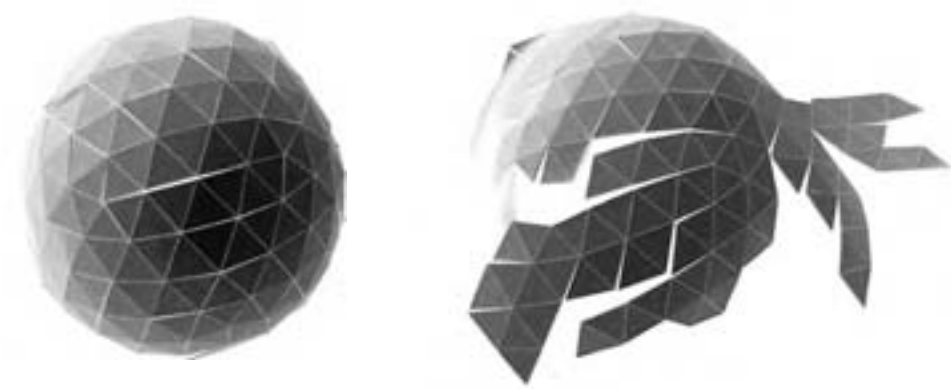

"Buckyball" (C60 atom structure) sphere tessellation into hexagons and pentagons.

# ARCHITECTURE

## CENTRAL CELL

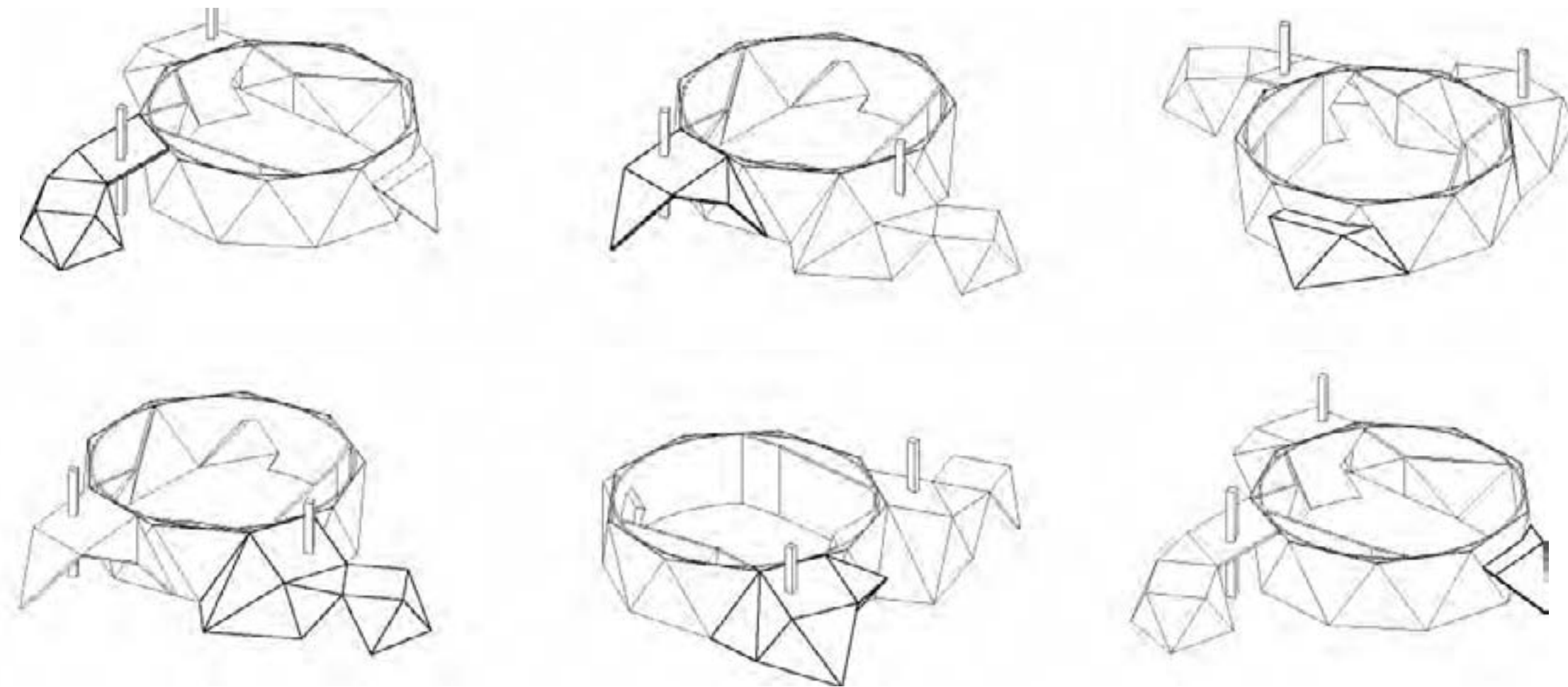

Central Cell with Sense Spaces.

Faceted and oblique surfaces transform envelop the column grid shaping alternative environments, acting as a threshold to shift the visitors' experience from the anthropomorphic scale to the nano scale. Rather than forming a backdrop for art in a traditional exhibition, the architecture of Nano actively forms a synergy with the exhibition media and the gallery visitor.

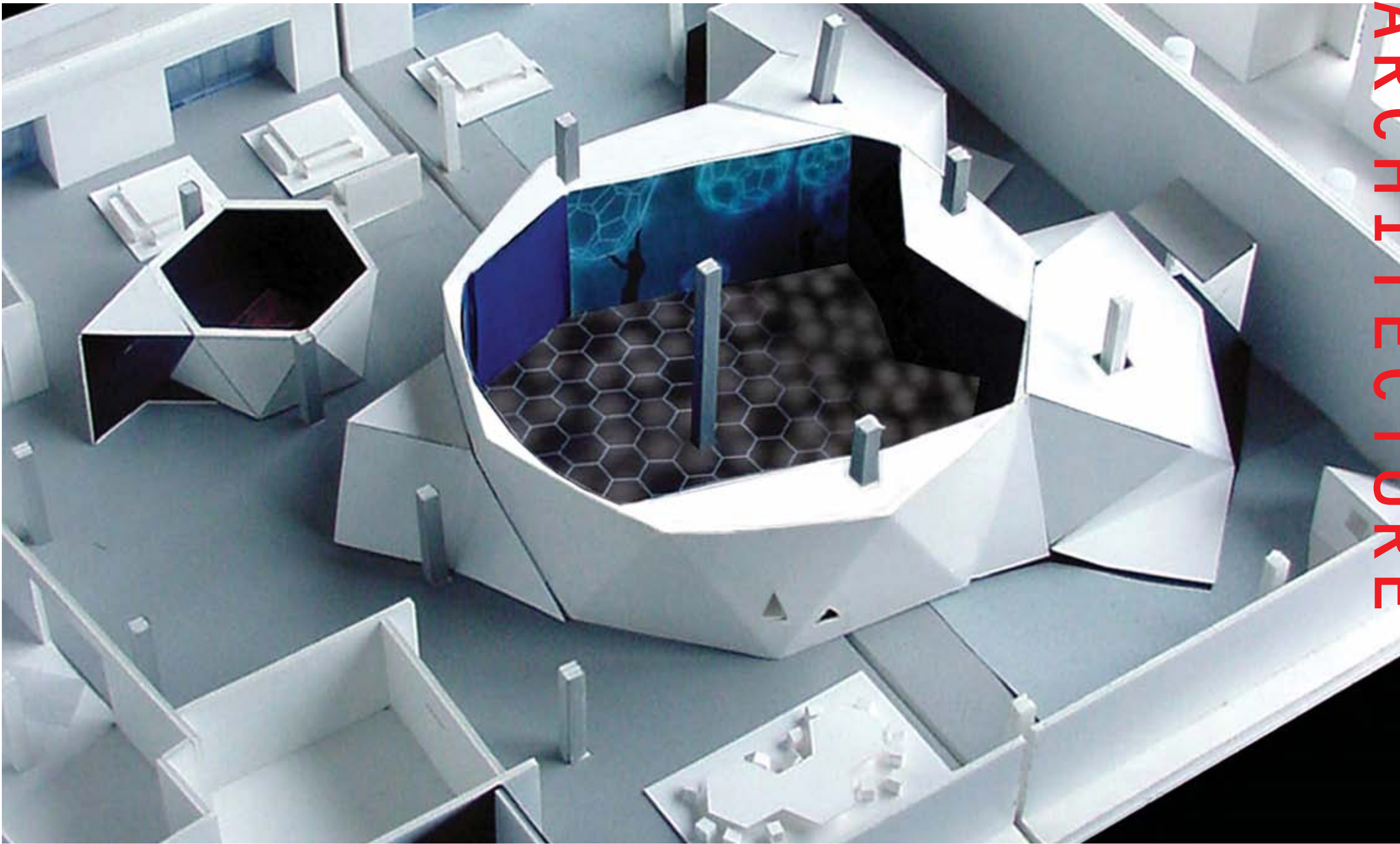

ARCHITECTURE

THRESHOLDS



Buckminster Fuller, Tetratable, 1975.

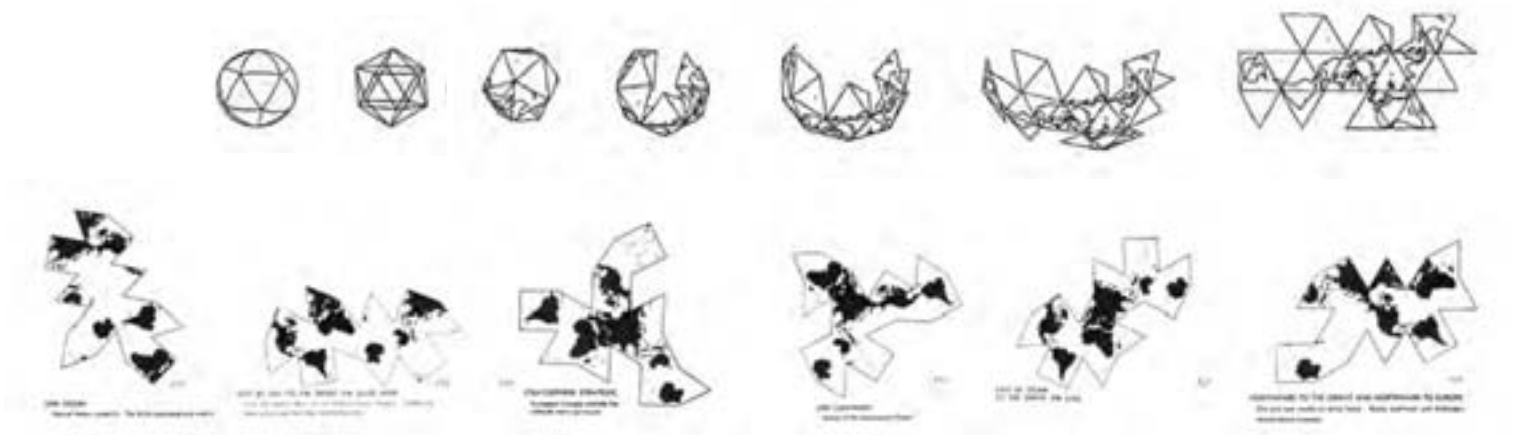

ABOVE: Fuller's Dymaxion Map, The spherical earth transformed into the most accurate 2D world map through topological transfer onto the triangulated faces of a polyhedron and subsequent unfolding into a flat surface.

BELOW: Buckminster Fuller, Different unfolding of the world map.

Operating between the logic of two and three dimensions, the surfaces and enclosures are derived from the geometric techniques and structural principles of Buckminster Fuller's Dymaxion world map- the unfolding of a three dimensional sphere into a two dimensional surface.

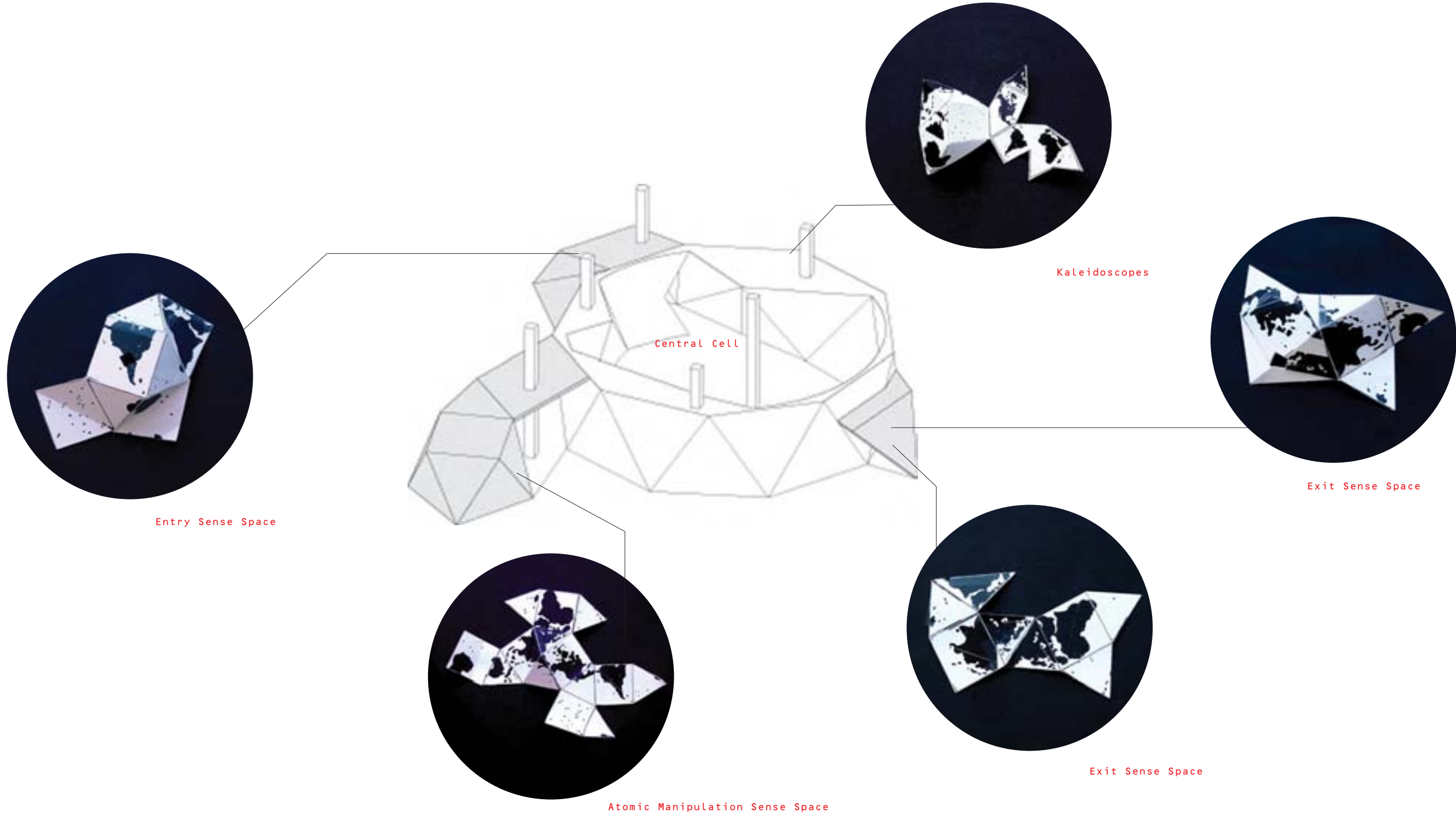

Sense Spaces unfolding Studies

# ARCHITECTURE

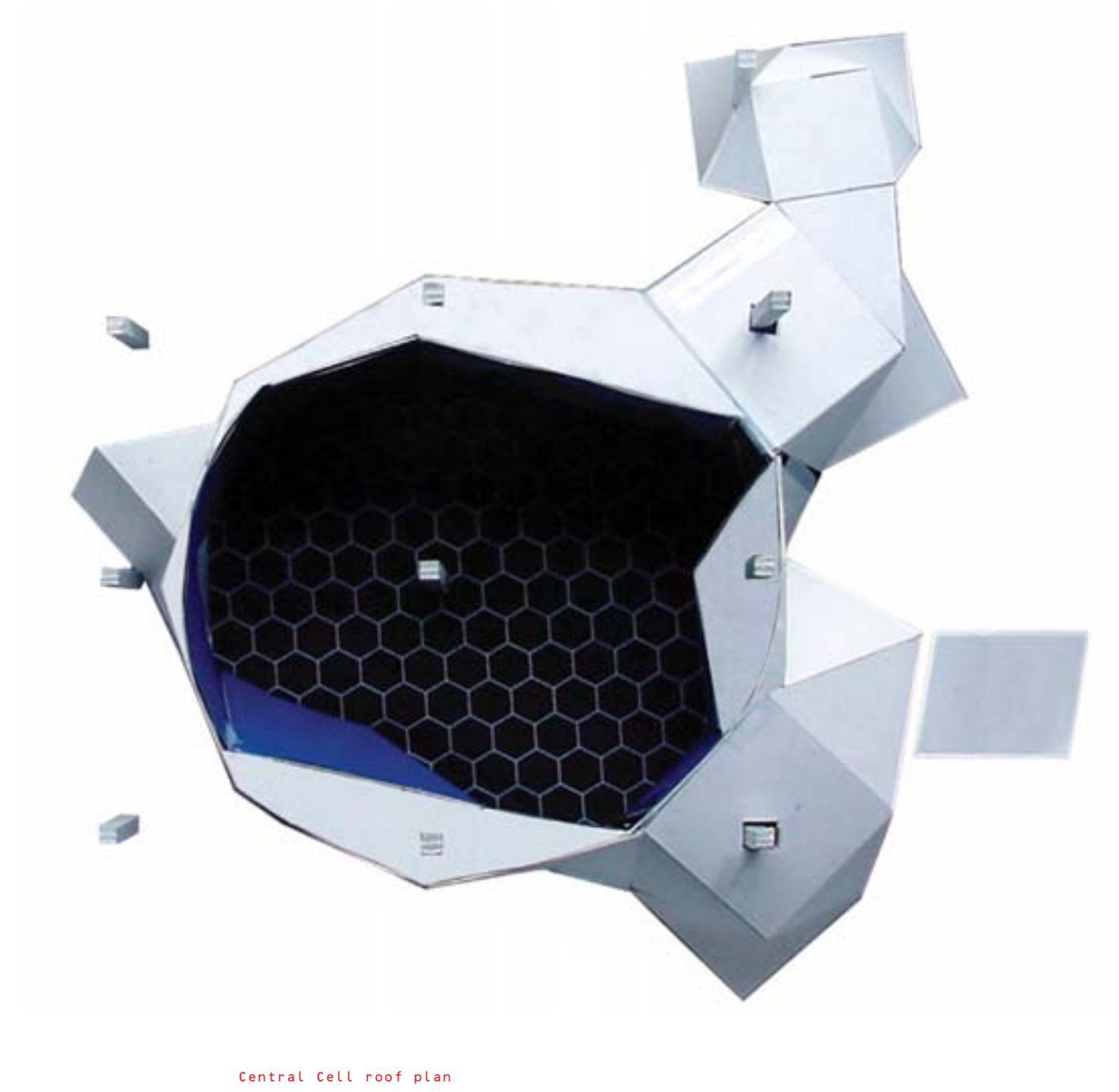

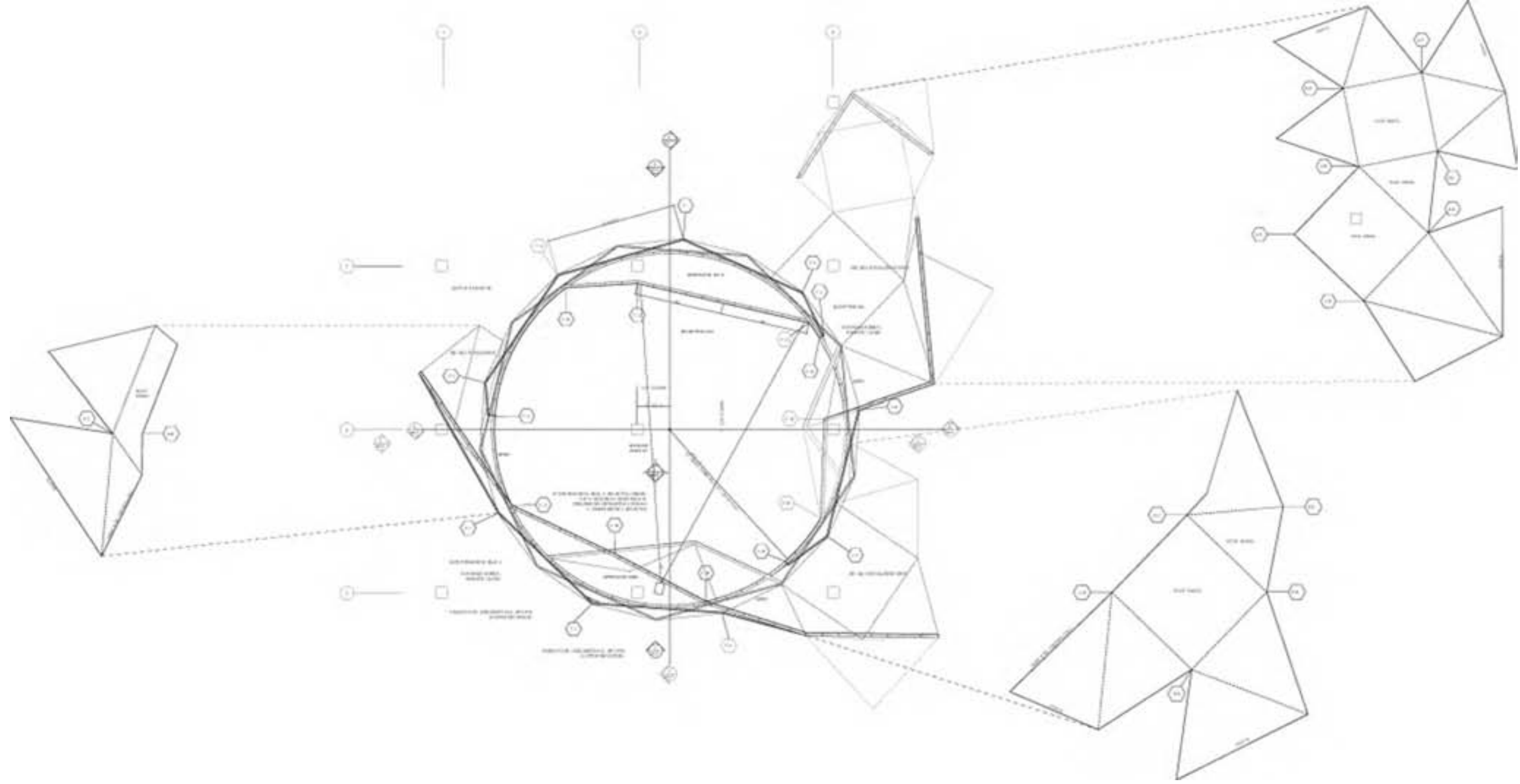

Construction assembly diagram  
of central cell enclosure.

# ARCHITECTURE

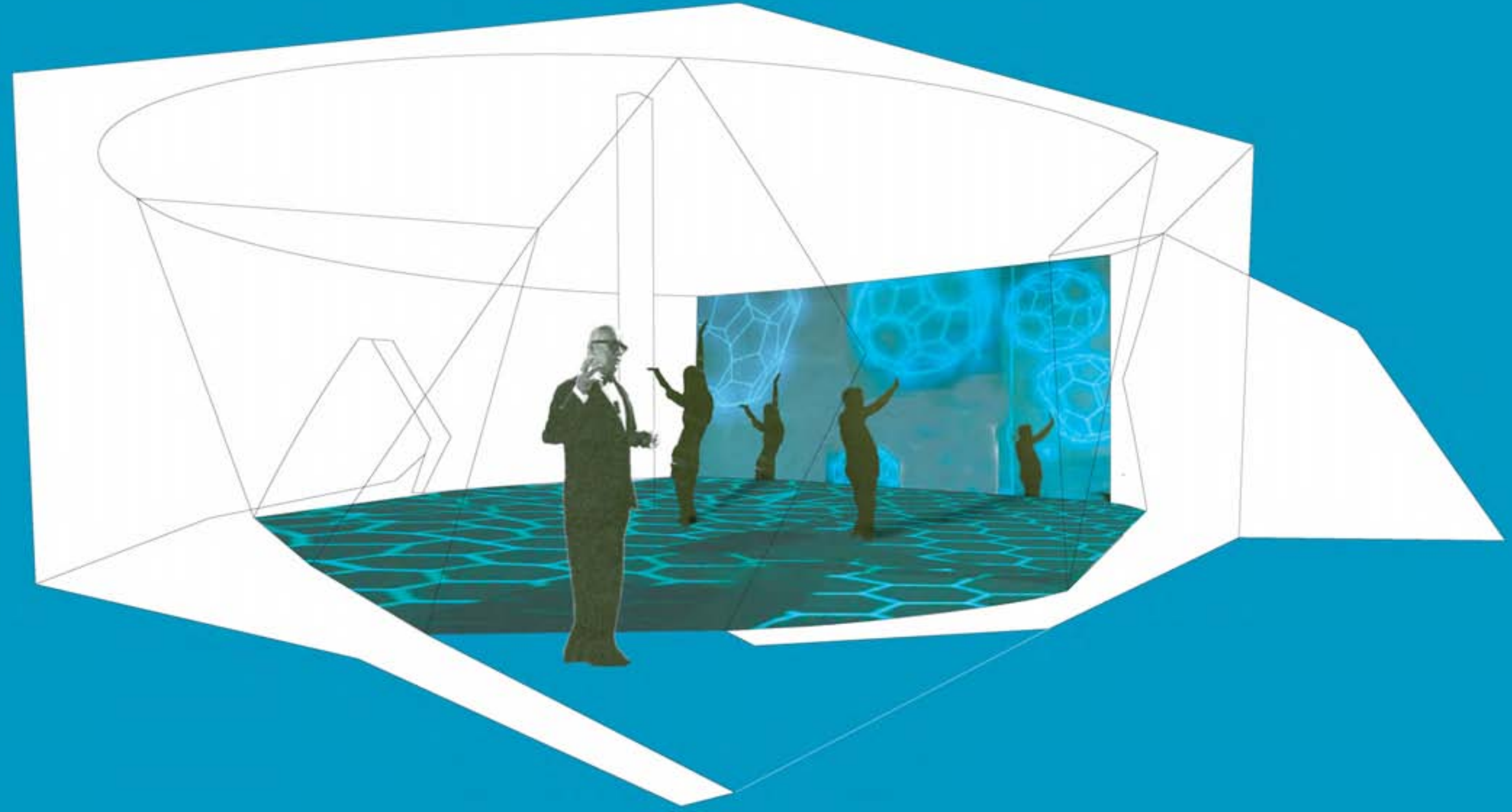



The exhibition under construction.



# ARCHITECTURE





ARCHITECTURE



# INSTALLATIONS

## INTRODUCTION ON INSTALLATIONS:

SOUND, LIGHT, AND WAVES DOMINATE OUR UNDERSTANDING OF THE WORLD AROUND US: THE SOUND OF THE SEA, THE IMAGES OF WATER AND SUN, DOWN TO THE SYNTHETIC SOUNDS AND TWO DIMENSIONAL IMAGES OF THE TELEVISION AND COMPUTER. OUR CONCEPTS OF MATTER ITSELF ARE DOMINATED NOT BY MATTER BUT BY THE WAVES REFLECTED, ABSORBED, OR CREATED BY MATTER. THE CONNECTIONS OF TECHNOLOGY AND CULTURE IN THIS SENSORY WORLD HAVE DOMINATED THE LAST CENTURY. THE SENSE OF BEING CONNECTED HAS BECOME INCREASINGLY DISTORTED BY THE ROLE OF SOUND AND IMAGES. BEING CONNECTED IS NO LONGER ABOUT BEING ACTIVELY PART OF THE ENVIRONMENT, BUT ABOUT BEING 'PLUGGED-IN', WIRED OR WIRELESS. THE CENTURY OF IMAGES AND SOUND HAS INCREASED OUR SEPARATION AND IN A PARADOXICAL WAY SEPARATED US FROM NATURE AND FROM EACH OTHER.

The industrial model, the materialistic visions offer little prospects for the future except more images, more sound more disconnection. Technologically and culturally we continue to be headed on a sad and predictable future becoming more disconnected from our own individual emotions, the sense of contact and the sense of small. The expression of science has also continued on a similar road of isolation and decline. The science museums despite all their valiant efforts have increasing dumbed down the science reducing it to a computer display, a few buttons to press or a series of mechanical gears wheels balls and lamps flashing alongside a textual explanation of what's going on. Watching the desperate frustration of children running from piece to piece, sensing their frustration and thinking is rather sad. A reduction of the magnificent inspiration, creativity and imagination that drives science to such a sad object based series of machines.

Nano is a process, a process of viewing science and art from the bottom up. It might seem paradoxical that nanoscience and media art, the two most technologically developed forms of science and art should be able to provide a fresh vision to humanity. After all they are both using the information technologies, the very machines that are responsible for our disconnection from the world around us. Nanoscience represents the science beyond the computer as we know it and the world of the last century. It's about reestablishing the connectivity, the sensory on all levels, its about the realization that we are

not machines but that all is connected, within and without. Nanotechnology is also about finding new paradigms to use this new awareness and requires visions and imagination that tend to be destroyed rather than nurtured by departmental teaching approaches and specialization. This science can probably be best understood as working outside the box in a trans-disciplinary fashion and taking a fresh and more informed view of systems rather than objects. Certainly the quantum mechanical picture of the world is much closer to the concept of sustainable systems and has application in societal and environmental approaches to our future. Nanotechnology is not an option but the only conceivable way at present to endure another hundred years of population explosion, the depletion of energy resources, the pollution of the air we breath and water we drink. Media arts itself has very similar goals from a human standpoint. The concepts of art as the object and the gallery visitor as observer have to be redefined. The connection the interaction through all the senses is in perfect harmony with the concepts of the non-Newtonian image. The common technologies involved and the desire for more sensory input and output truly connected to the world as a whole and your self as a deeper experience are fundamental to this art form.

The process of bringing together the directions of hope with such common goals is not easy. For every great proposition there is an equal opposition. The biggest is the stereotypes that are a mindset of society about art and science and the definition of

a new third culture. The ability of artist and scientist to work as equals and be recognized as such is very difficult to convey to the public and peers. The acknowledgement that such a collaboration can indeed lead to a deeper inspirational and hopeful view of society and technology and that the minds of children can be inspired by that image is what we set about to do at nano. To provide a sense of connection that is beyond visual that is truly participatory, where the visitor creates the art, creates the waves, perturbs the environment. A place where his role their influence, presence and imagination is acknowledged and their trace remains.

NANO EXHIBITION FLOORPLAN:

- 1. entrance
- 2. central cell
- 3. atomic manipulation table
- 4. nanomandala
- 5. quantum tunnel
- 6. fluid bodies
- 7. kaleidoscopes

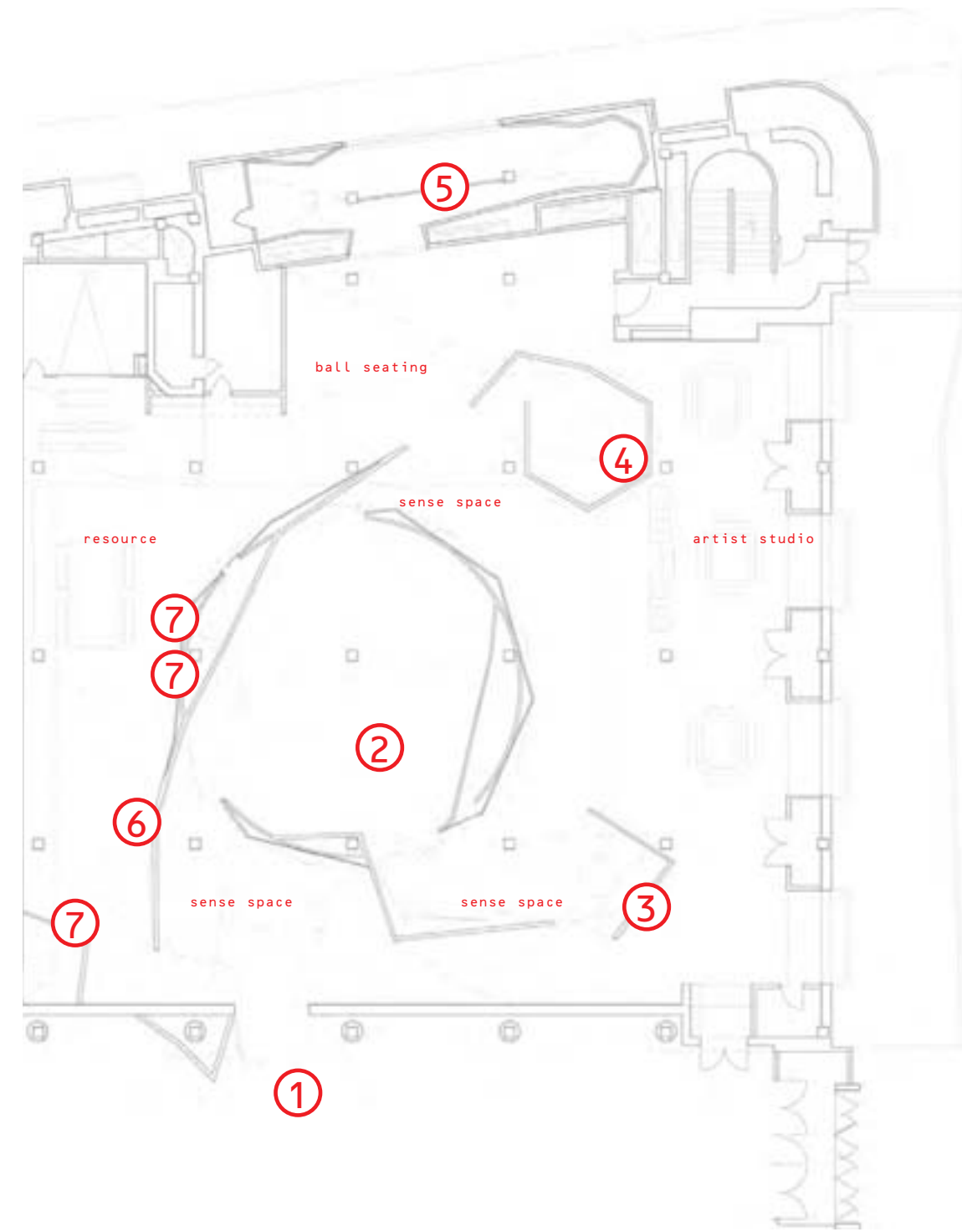

INSTALLATIONS

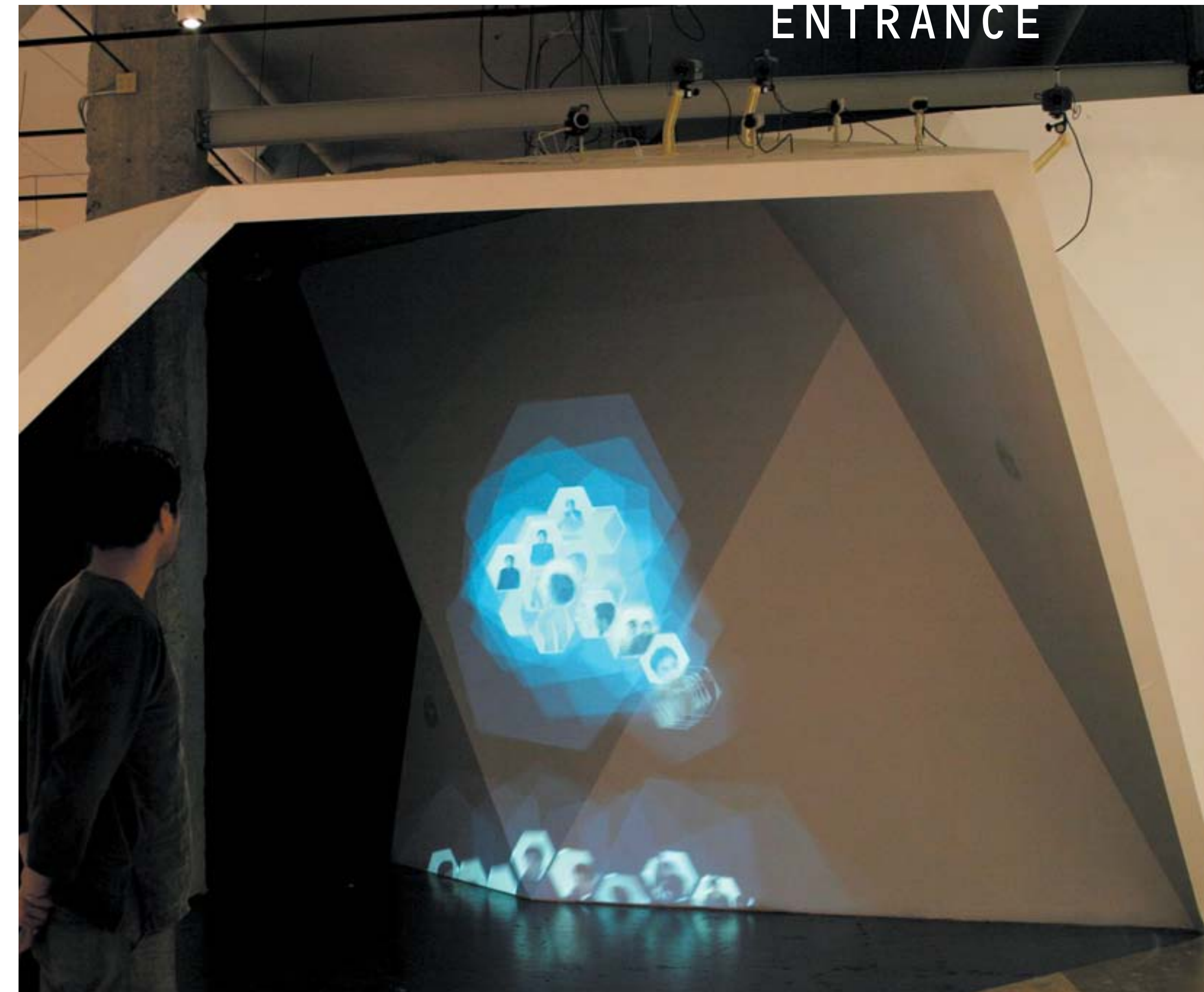
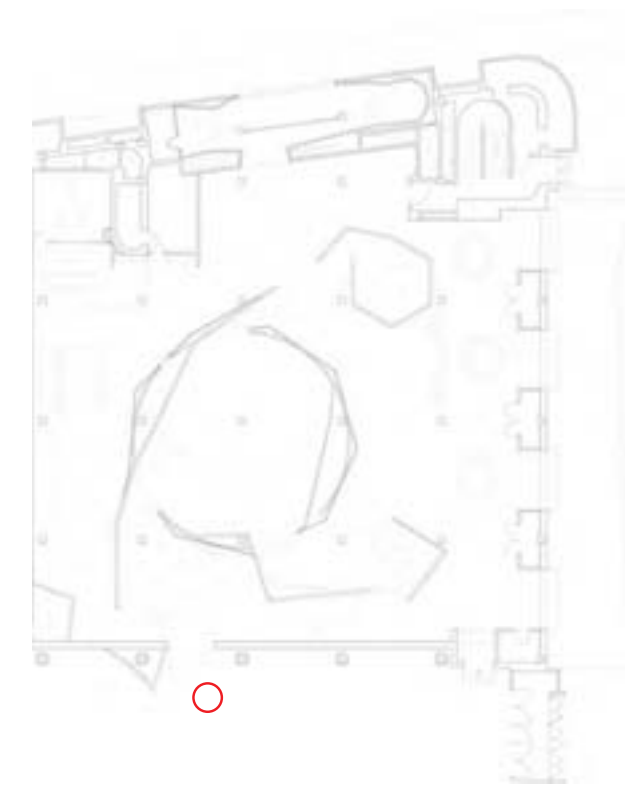

Immediately the observer is observed. A swarm of cameras captures HEADS of all who enter and individuals are mapped onto hexagonal MOLECULES, seen on the wall facing the entrance. These molecules attract each other, and slide towards the inner cell in movements derived from Brownian motion, and a kind of self-assembly seen in carbon molecules.



The nano team 'swarm' can be seen along the entrance wall.

# INSTALLATIONS

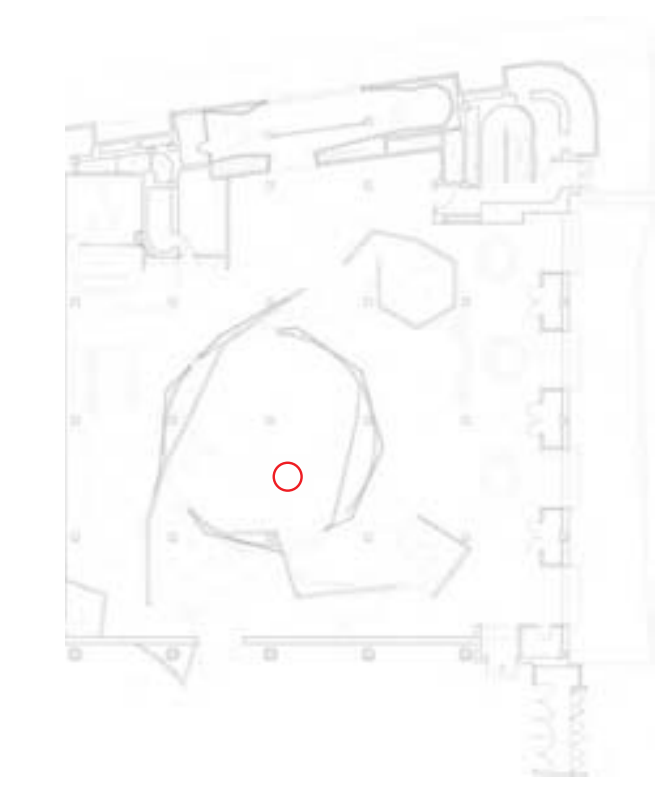

The installation's folded architectural surfaces spiral toward the inner cell, which is inspired by the smallest unit of life capable of self-sustaining existence and replication. Within the cell, macroscale phenomena are converted into microscale and vice versa, introducing the analogy with nanospace and the play on scale that runs throughout the exhibition. The wall projection shows the structure of carbon-60, part of a class of carbon molecules that have an extremely stable geodesic-sphere structure. Carbon-60 was first discovered using nanotechniques and named buckminsterfullerene (or more informally, BUCKY BALLS) after Buckminster Fuller, an engineer, architect, philosopher, and visionary who

invented the geodesic dome - the lightest, strongest, and most cost-effective structure ever devised. Buckyballs, projected here in varying sizes, do not follow classical laws of motion but rather interact as microparticles would. The interactive floor, showing hexagonal structures characteristic of carbon in the form of graphite, is triggered by physical movement from visitors to create 'gravity waves' and set off sound effects.



ALLEGRA FULLER, Sir Buckminster's daughter, reaches for a Buckyball.



The hex floor is created by four projections mirrored downwards.

# INSTALLATIONS



JEFF CHONG - HEXFLOOR BEHAVIOUR

In an engineering vision interaction of particles is treated by Newtonian mechanics. For instance, two moving billiard balls only interact at the point of contact. On the nanoscale, two atoms, even though separated by significance distances, interact through waves. These quantum mechanical phenomena can be observed with the scanning tunneling

JEFF CHONG is testing the hex floor behaviour with infrared light.

Setting up the hex floor.



microscope. The hexagonal floor is a dynamic projection that conveys the communication of atoms on a quantum scale. In the central cell, visitors assume the behavior of atoms and this shift their normal expectations of action and reaction. A hexagonal structure representing the pure carbon in the form of a graphite lattice is projected on the floor becomes the medium to communicate

the wavelike properties of atoms through waves which dynamically are emitted and observed by the participants. Each person's waves interfere with the other, creating complex dynamic patterns resembling water droplets falling into a pond. Just as two humans entering a room do not behave as Newtonian billiard balls, atoms share a strangely analogous and similar awareness

of each other's presence. The juxtaposition of quantum awareness and human awareness was the underlying theme of this installation.

DANIEL SAUTER working on the remote control of the robotic spheres in the central cell space. The idea was to have the movement of the spheres controlled by the audiences outside the central cell at the atomic manipulation table. In this manner, the spheres are influencing the movement of the humans in the cell space. Thus we show the interconnected nature of manipulation through technological means on the human social sphere.

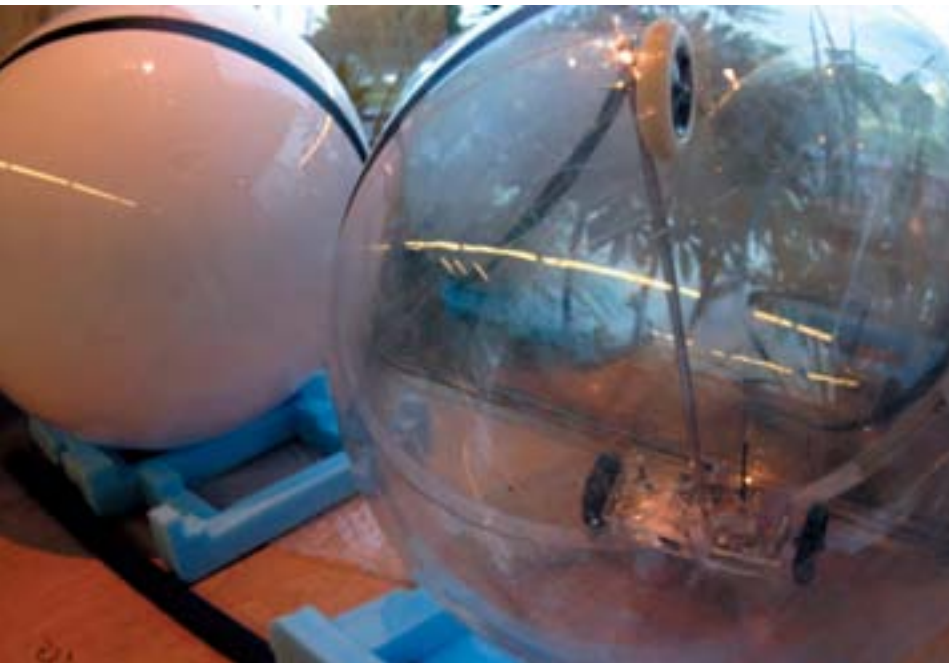

The graphite floor programmed by JEFF CHONGSTEIN simulates the graphite carbon.

# INSTALLATIONS

Late night at the central cell - VICTORIA and ANDREW playing with the half spheres.

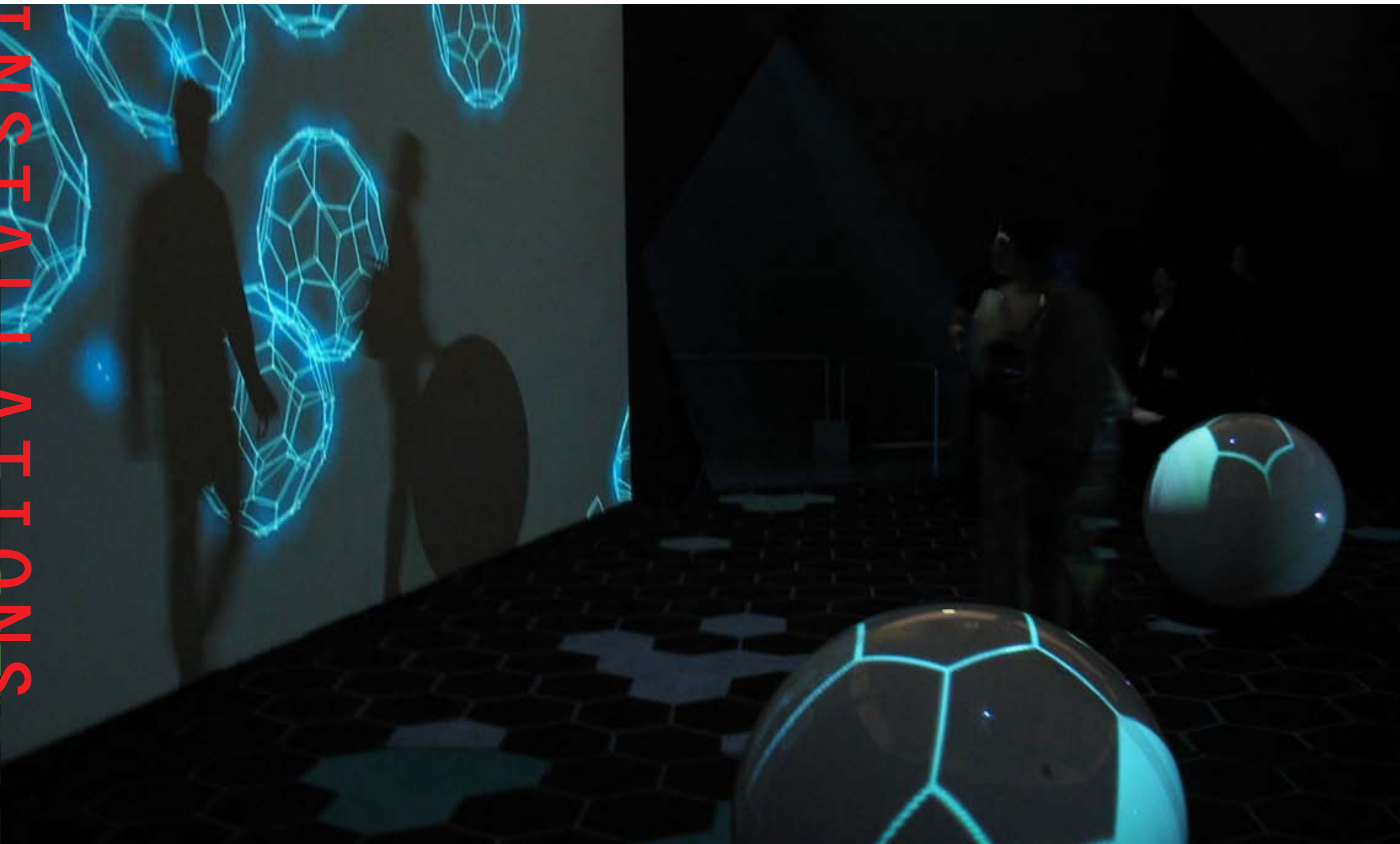

During the exhibition another version of the floor was developed. Buckyballs are not only manipulated by the shadows on the wall but are moving around the entire space immersing the audience. This installation is inspired by Gimzewski's nanoscale work on the actual repositioning of individual buckminsterfullerene molecules which are an icon of nanotechnology and the creation of new molecular forms of matter.

Participants become the apex of the scanning tunneling microscope perturbing and shifting molecules across the surface. The motion of the molecules faithfully represents the non-newtonian, the presence of stochastic brownian motion and the lack of inertia that prevails on the nanoscale as well as the forces that drive self assembly.

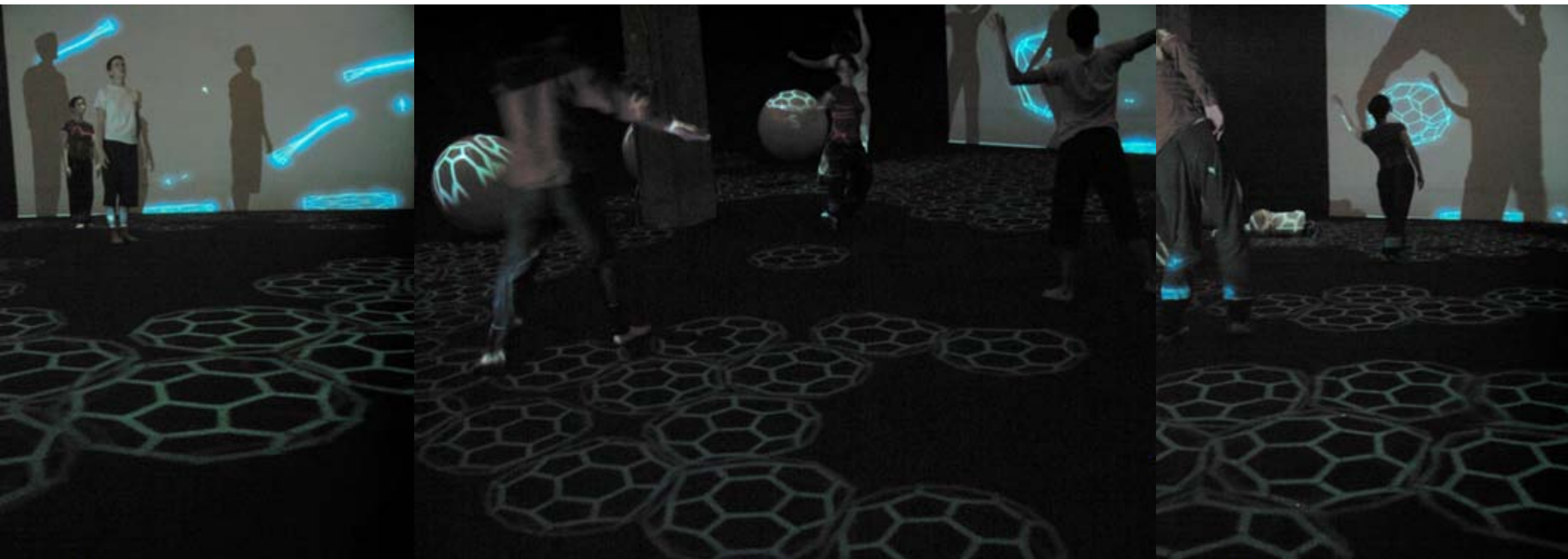

# INSTALLATIONS



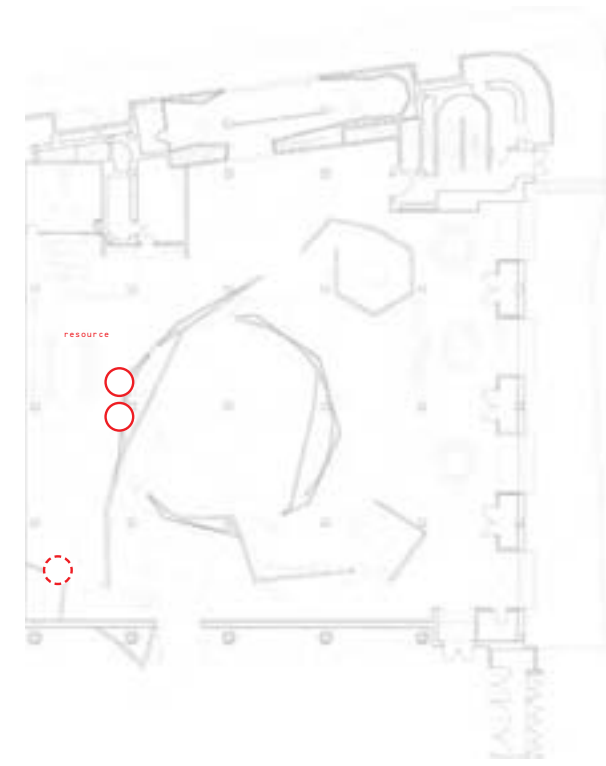

## KALEIDOSCOPIIC VIEW OF INNER CELL

There are three kaleidoscopes in NANO. This is the view from the two looking into the inner cell from the resource area (see images next page).



## KALEIDOSCOPE



# INSTALLATIONS

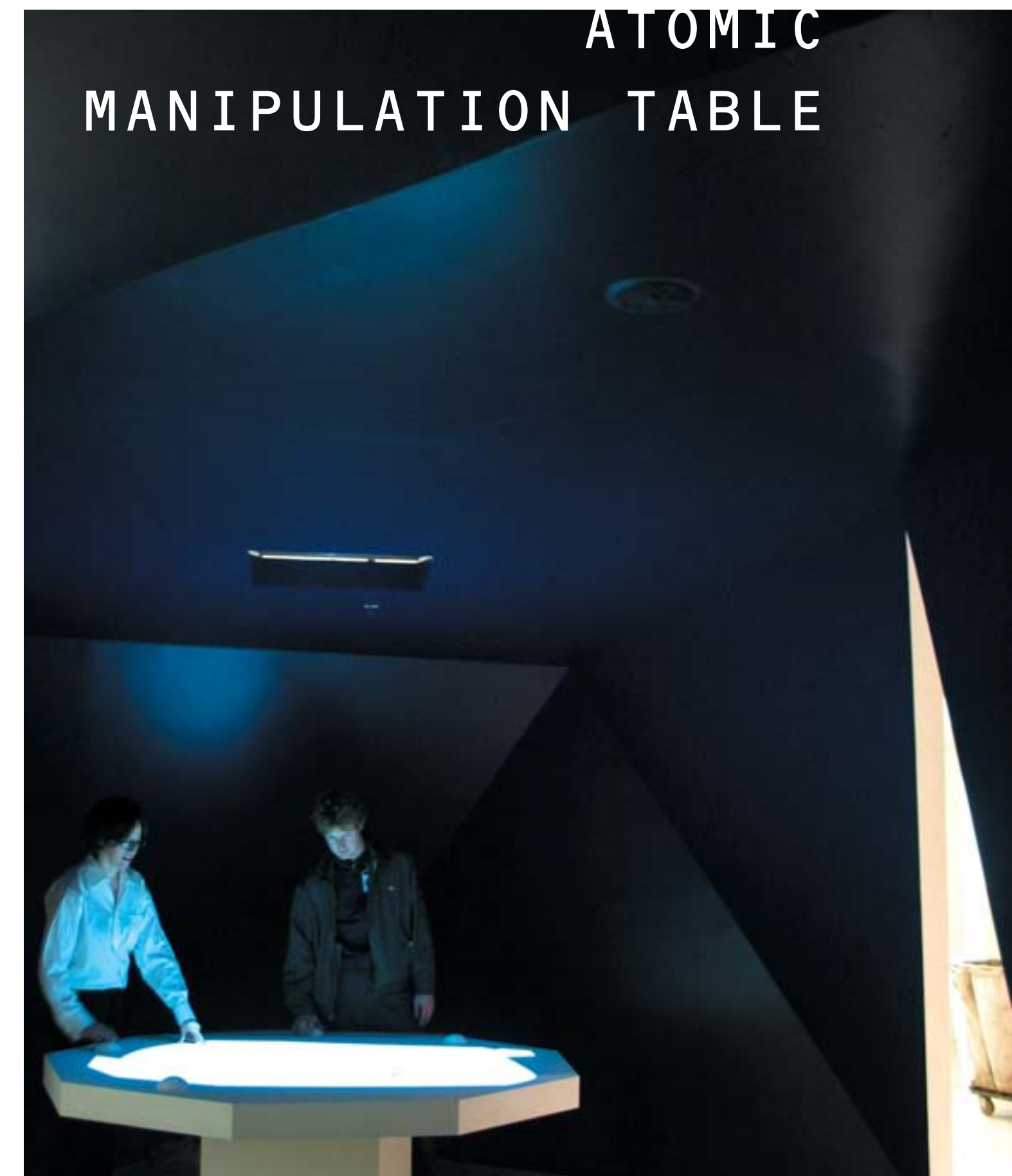

Nanotechnology was certainly inspired by the recent ability to purposefully manipulate atoms and molecules on an individual basis. In this installation, the visitors in the central cell are observed by a camera placed in the central cell. The images have an ethereal quality reminiscent of the scientists' experience working in the laboratory while remotely manipulating molecules.

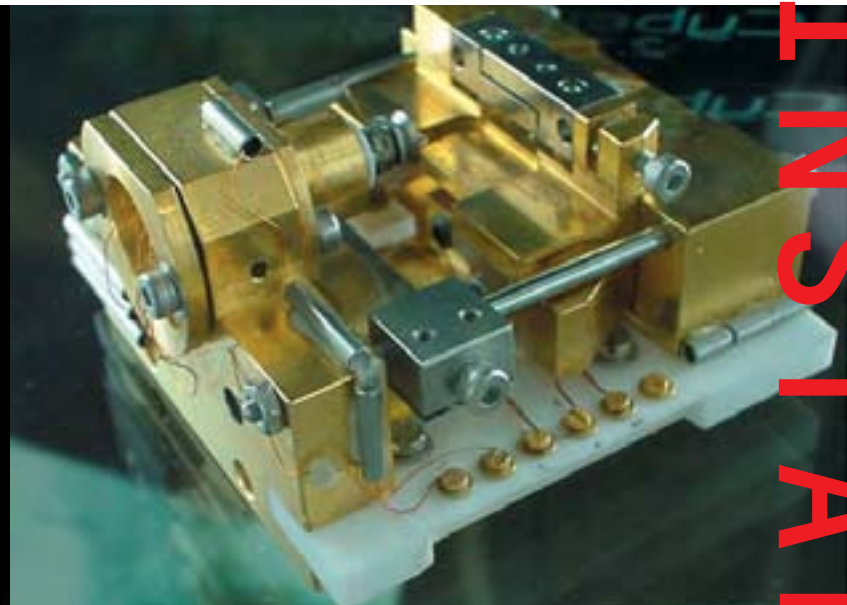
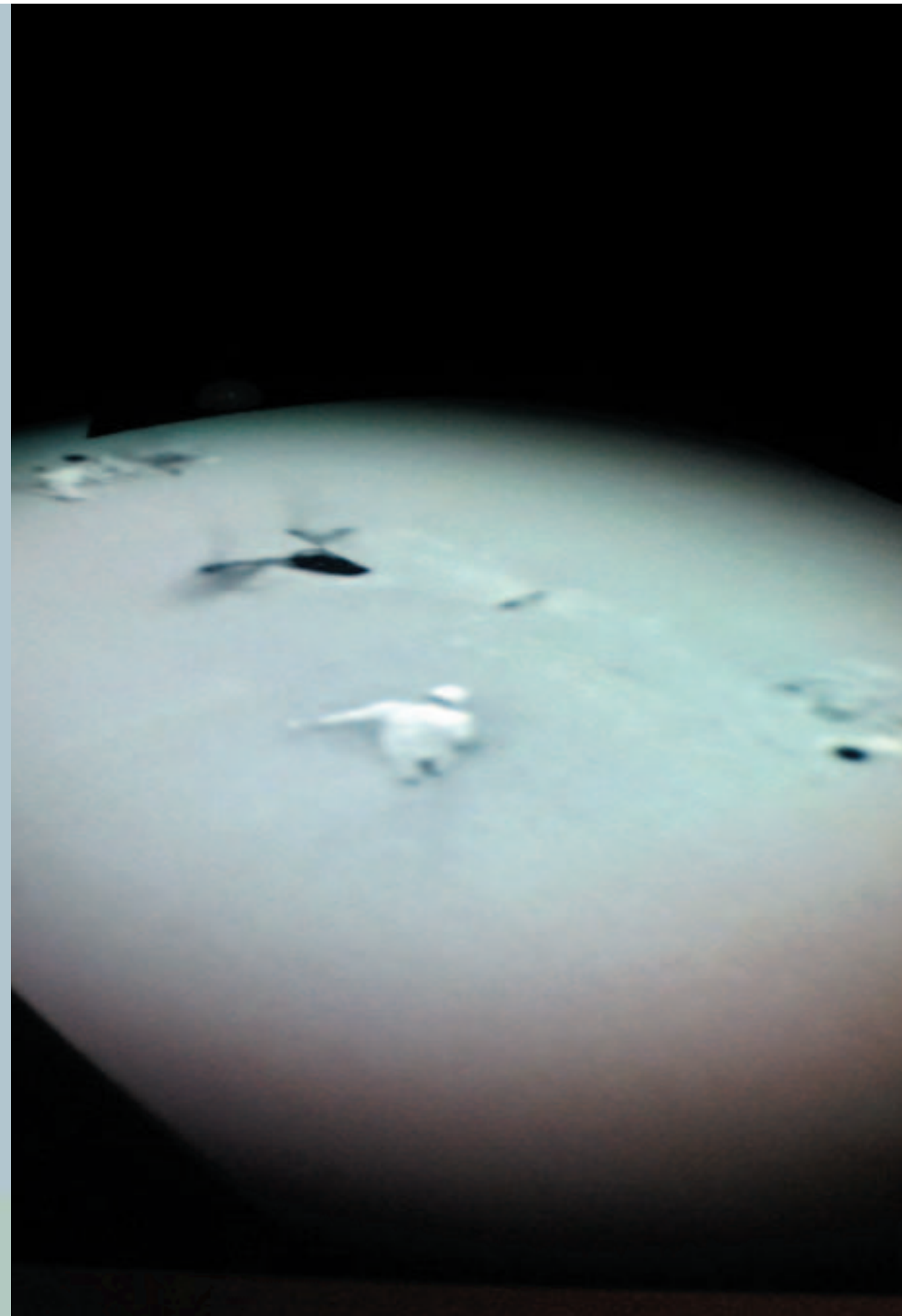

Scanning Tunneling Microscope designed to manipulate molecules at ultra low temperatures.

# INSTALLATIONS

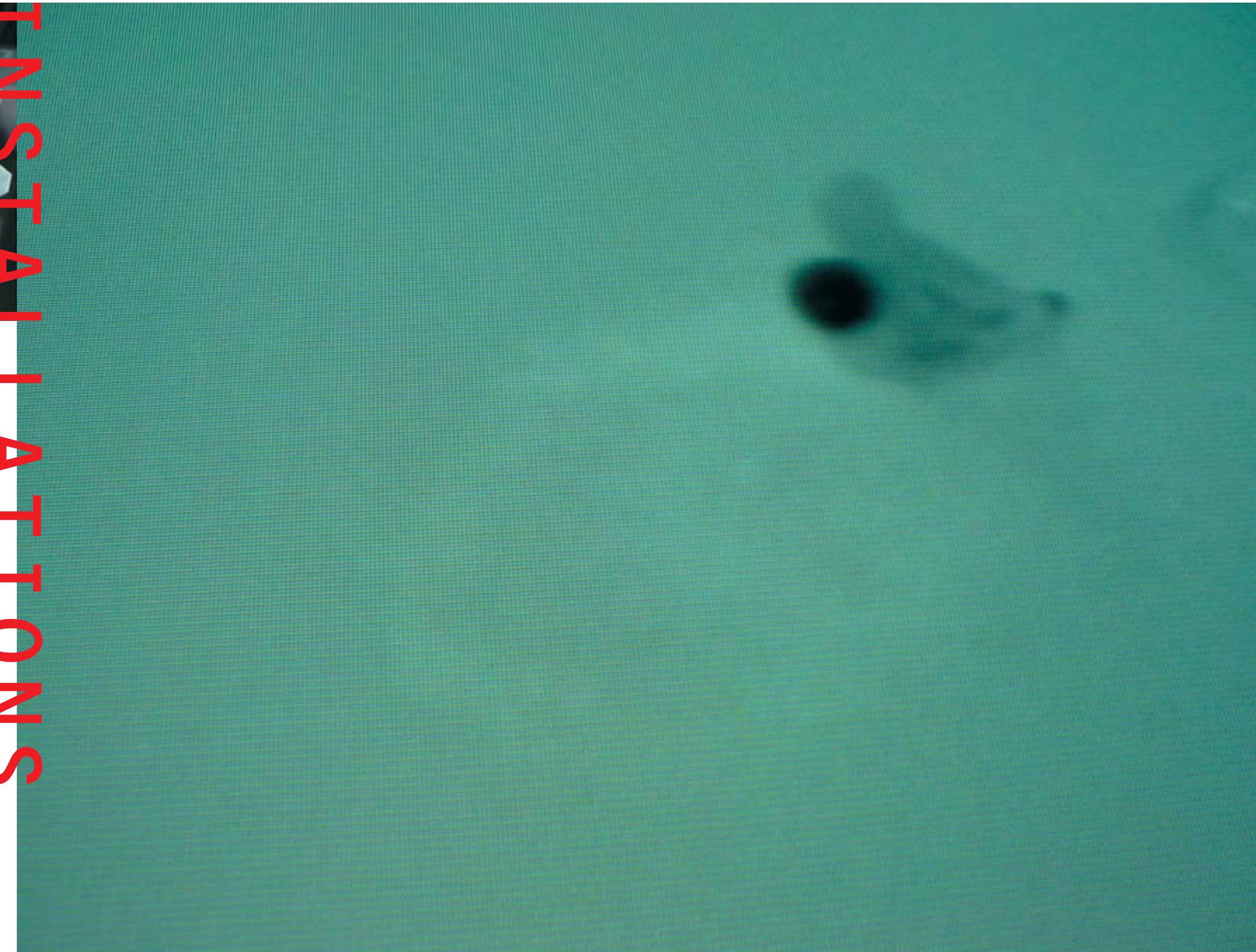

"WHAT I WANT TO TALK ABOUT IS THE PROBLEM OF MANIPULATING AND CONTROLLING THINGS ON A SMALL SCALE."

RICHARD FEYNMAN, 'THERE'S PLENTY OF ROOM AT THE BOTTOM', 1959.

INSTALLATIONS

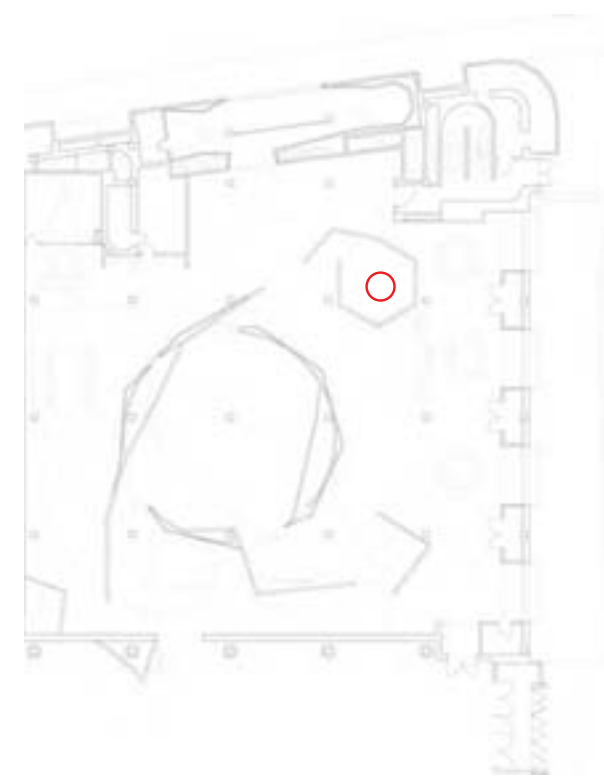

One month before the opening of nano at LACMA West, an exhibition of Tibetan and Nepalese Buddhist art, *CIRCLE OF BLISS*, opened at LACMA East. One of the elements of this exhibition was construction of a eight-foot-diameter sand mandala of Chakrasamvara by Tibetan Buddhist monks from the Gaden Lhopa Khangtsen monastery in India. This particular sand mandala has never before been made in the United States. The image at left is onsite at LACMA, October 3, 2003. Victoria and Jim decided that this was a wonderful way to connect the main museum to the experimental wing, and the practice and process of seeking knowledge of the East and West.

The Tantric Buddhist tradition of 'painting' with colored

sand evolved as a means of consecrating the planet and its inhabitants to bring about purification and healing. The monks begin by drawing the outline of the mandala on a wooden platform. The next step of the process, which will continue over three and a half weeks, is the careful pouring of sand from the traditional copper chak-pur. Holding this narrow copper funnel, the monk (generally four work simultaneously, dividing the piece in quarters) runs a metal rod over it, and the resultant vibration causes the sand to flow like liquid.

Working from the inside out, the highly skilled monks meticulously create the mandala's three levels of understanding: the secret (which represents the primordial

perfect balance between the body and the mind), the inner (a map to guide the ordinary human mind on its quest for Enlightenment), and the outer (the world in its divine form). To reinforce the understanding of the nano scale, one installation connects to the process of the recent creation of a sand mandala at LACMA, from a nano-scale view of a grain of sand to the completed eight-foot mandala. The monks were generous enough to visit the Pico lab and recreate the center of the mandala that was images first with the scanning electron microscope, then a regular microscope. The final photographing took place when the mandala was completed with over 300,000 images taken to create the illusion of descent into and beyond the grain of sand.



# INSTALLATIONS



Tibetan monk building a copy of the center of the mandala at the Pico Lab, UCLA.

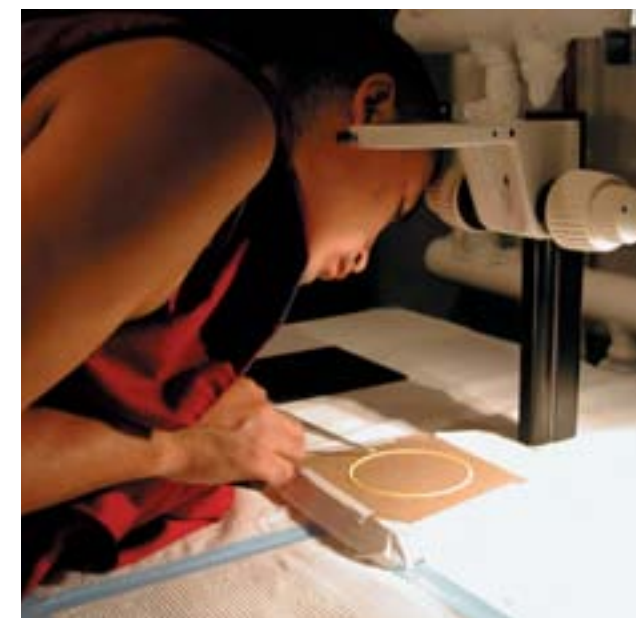

The Chakrasamvara Mandala.



The Mandala shoot in progress.



INSTALLATIONS



Audience interacting with the sand and projection.

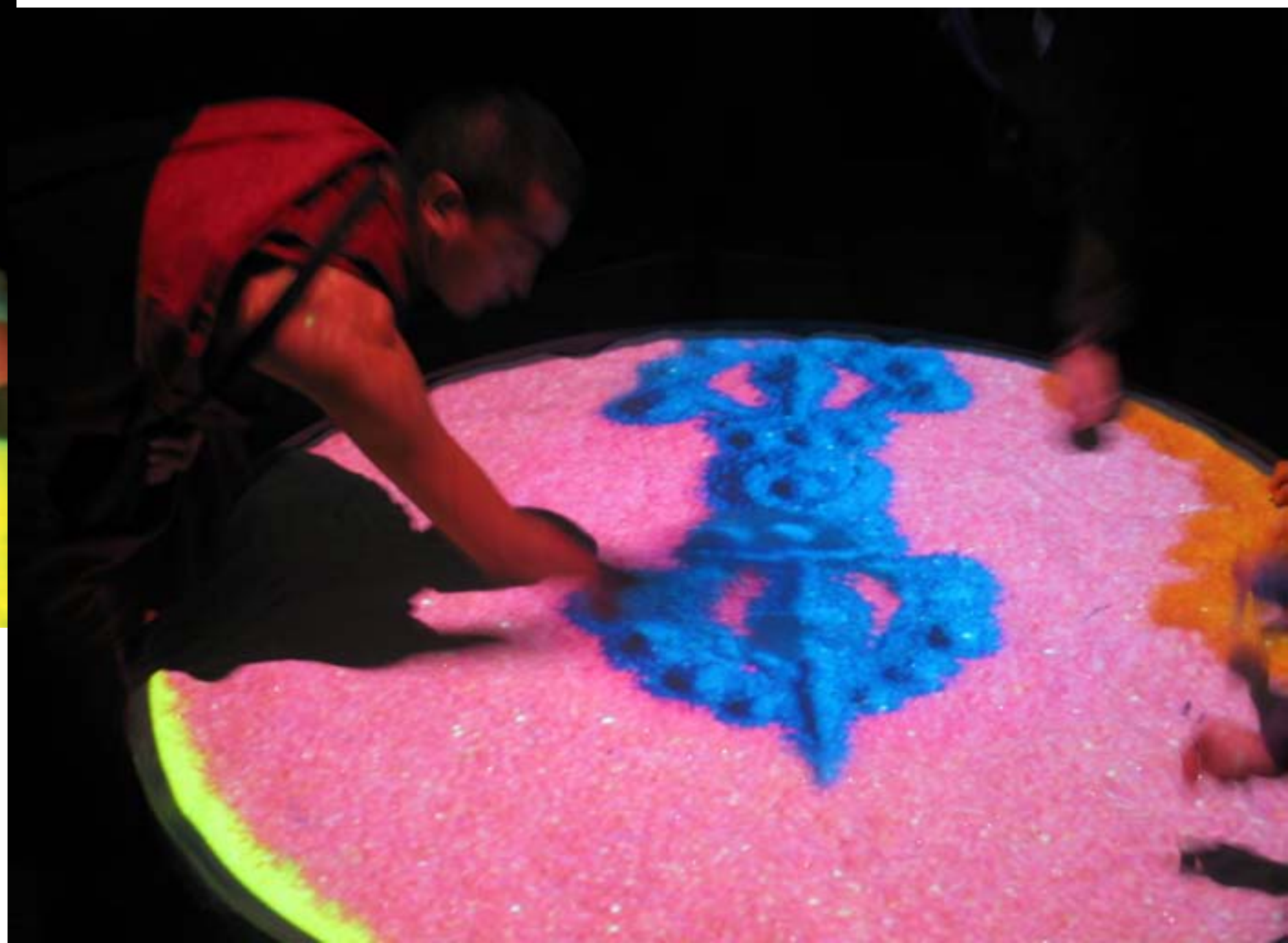

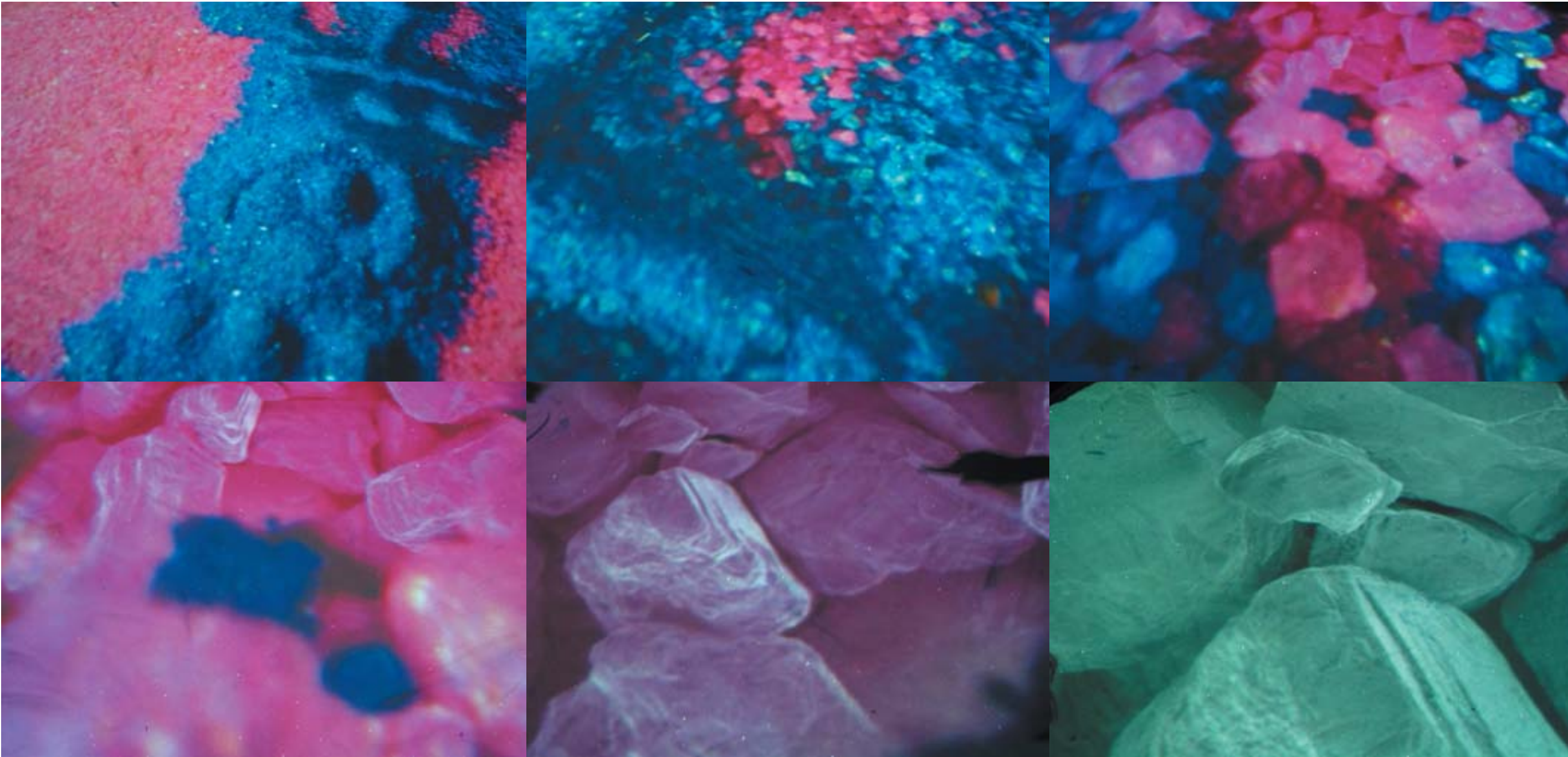

INSTALLATIONS



At the atomic and subatomic scale, quantum forces result in behaviors that, from an everyday perspective, are counter-intuitive. One example is the ability of an electron to penetrate a barrier even though it does not have sufficient energy to leap over it, an effect called tunneling. This effect comes into play with a scanning tunneling microscope (STM) when electrons tunnel between the STM tip and the surface of the material being probed, an effect central to the investigation of the nano world. Quantum mechanics describes this as a SUPER POSITION, since the electron appears to be at the tip and on the surface simultaneously. The quantum tunnel installation provides visitors with a playful, metaphoric

interpretation of these phenomena. When visitors stand in the identical rooms at either end of the tunnel, their faces are captured on camera. The images are then converted into PARTICLE CLOUDS, as if they had become part of the electron cloud swarming around an atom's nucleus. When another



visitor passes through the tunnel connecting the two rooms, the tunneling causes disturbances in the projected images and results in the images being merged, as if the visitors had tunneled into each other's identities.



# INSTALLATIONS

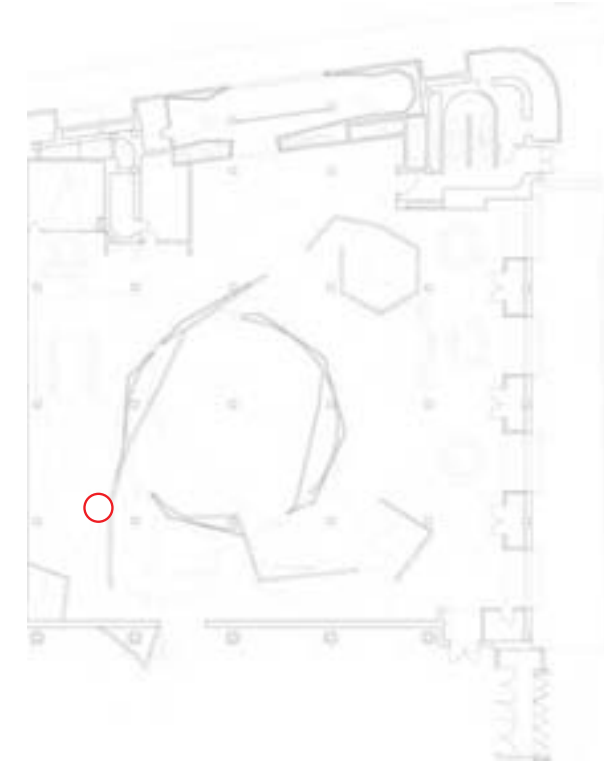

# FLUID BODIES



Particle clouds form a mirror image of you walking away and memorize the action as your image scatters away. Later, your image will reappear making the same motion, only to be scattered away again by movement. Words, too, appear and dissolve into particles. On a nanoscale, each particle has a large influence on the energy fields around it.

Both the online and exhibition versions of the NANO logo are based on particle aggregates.

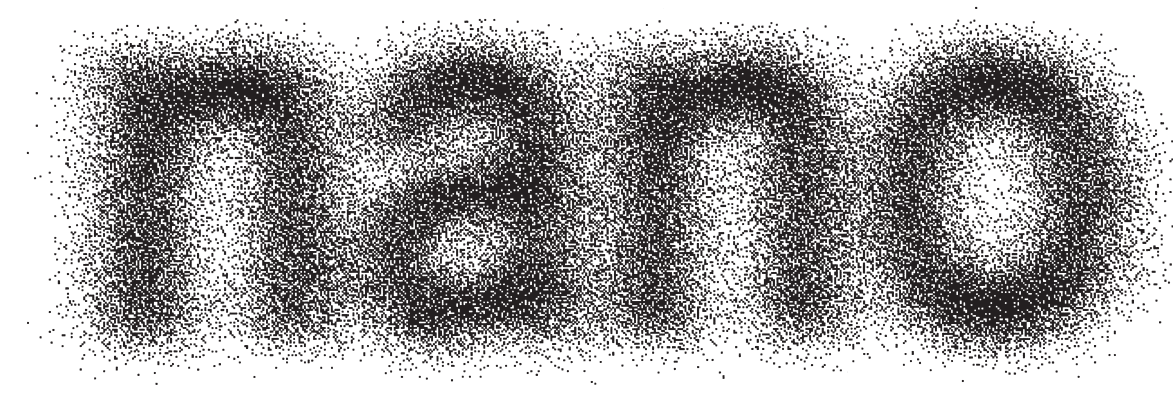

# INSTALLATIONS

"THERE IS NO STABILITY IN THIS WORLD...  
ALL IS EXPERIMENT AND ADVENTURE.  
WE ARE FOREVER MIXING OURSELVES WITH  
UNKNOWN QUANTITIES."

VIRGINIA WOOLF, THE WAVES, 1931.

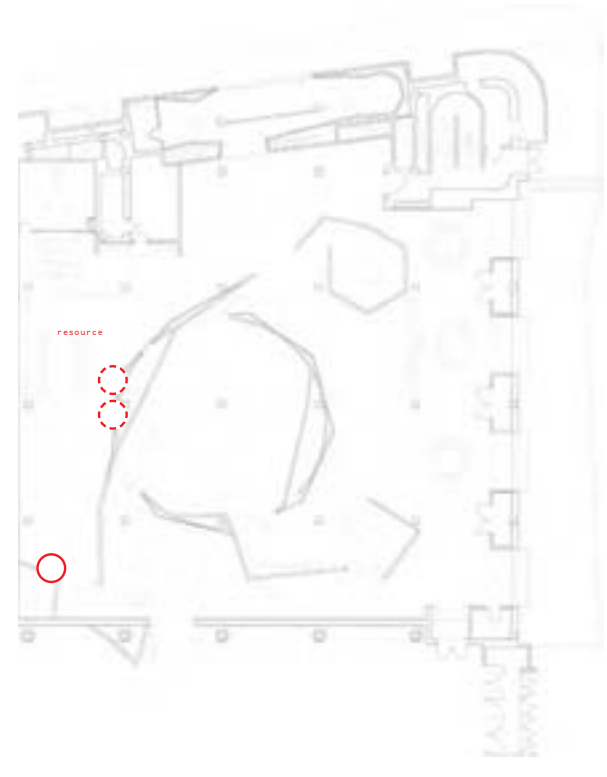

## KALEIDOSCOPIC VIEW NANO MANDALA

There are three kaleidoscopes in NANO. This is the view from the third hexagonal kaleidoscope in the south east corner of the gallery. (see images next page).



# KALEIDOSCOPIC VIEW



UCLA Vice Chancellor of Research,  
Roberto Peccei Looking in.





# SOUND

The audio team: ANNE NIEMETZ, TENZIN WANGCHUK, and ANDREW PELLING painting the speakers for the nano-mandala room.

The base for the sand mandala built by the monks is traditionally painted a special blue symbolizing the heavens. The same paint was later used by the nano team for the base of the nano-mandala to mirror the process and the metaphor. Speakers, as everywhere, are embedded in the architecture.

**SOUND** is an important element in the entire exhibition. It is specifically designed to enable and motivate movement and immersion within the spaces.

In the transitions to and from the Central Cell, keywords about nanoscience echo through the tunnel. Words such as 'nanotechnology', 'molecules', 'genes', and 'virtual' are spoken in various languages and tones, stated and whispered by different voices, often synthesized or disassembled. The interactive

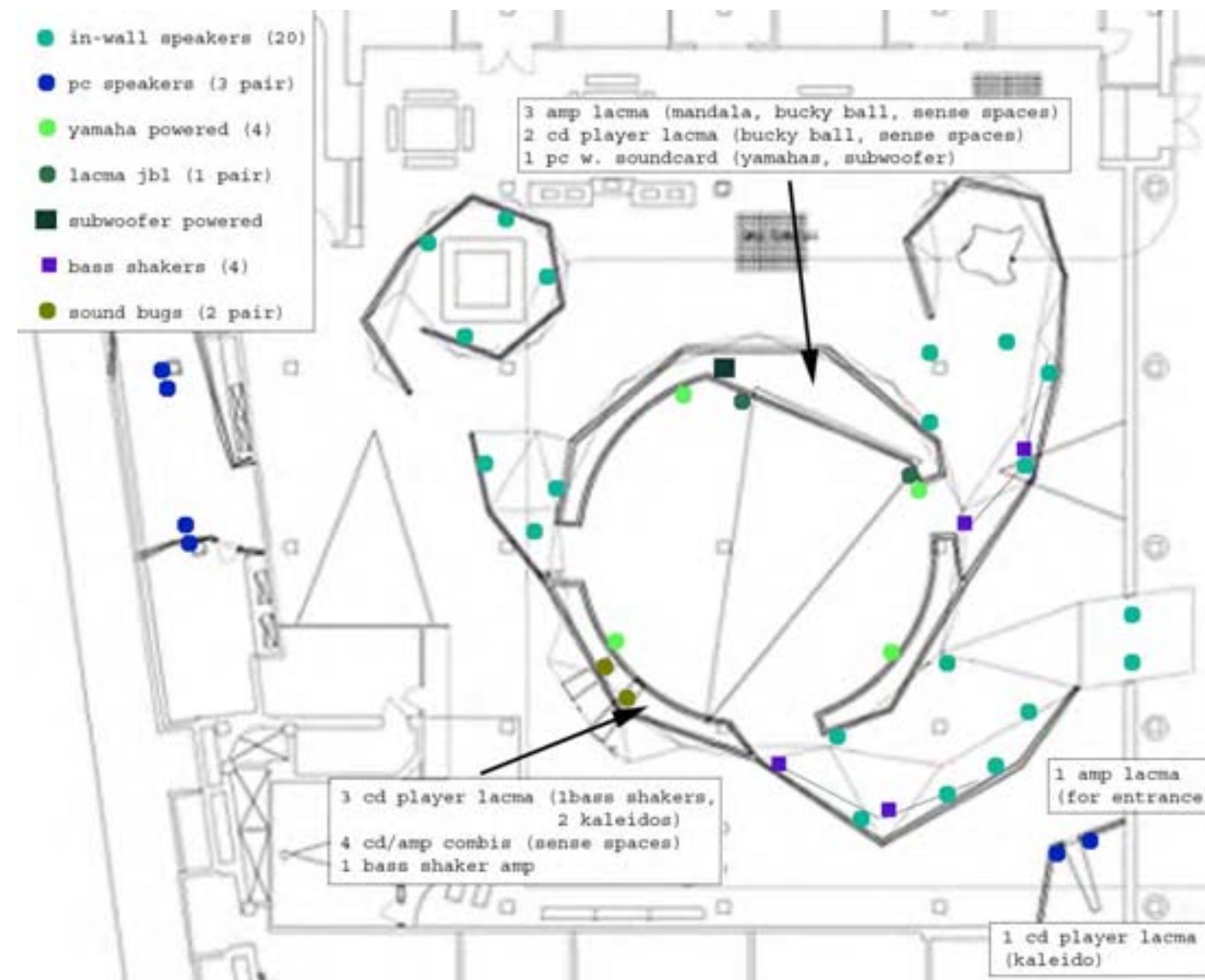

buckyballs emit a chiming sound that complements the bass frequencies in the inner cell. The visitor looking into the kaleidoscope hears a voice reciting a quotation from science fiction. The combinations of fractured visual image and fictional narrative differ in each kaleidoscope, and together elaborate the connections between the exhibit's visual and textual elements. The soundtrack in the Nanomandala space is derived from sounds recorded during the process of making the sand mandala, combined with sounds from nature.

Sound layout for the nano space.



## RESOURCE SPACE

Nano is designed to immerse the visitor in the molecular world and prompt questions, not give answers. For those curious to find out more about this fascinating world, there are numerous books from the scientific, sci-fi and literature world.



Jitterbug (a cub octahedron that Buckminster Fuller used to demonstrate transformations between geometries) on loan from the Buckminster Fuller Institute.



The tensile structures that appear in the molecular world and the physical architecture can also be assembled at the resource table.



# ACTIVITIES

## THE CRYSTAL METHOD

Holding a specially designed tool and wearing 3-D glasses, visitors draw in space, causing crystal particles to appear and lock together in a lattice formation. Visitors perceive the created shapes floating in space and can grab, rotate, and shake them with special sensed tongs. This installation reveals crystal structures found at the nanoscale.

This three-dimensional interactive work is based on interface research conducted by Steven Schkolne with Peter Schroeder at

the California Institute of Technology (Caltech). The technology of The Crystal Method is potentially applicable to research in nanoscience.

Many Thanks to the California Institute of Technology, DesignworksUSA, and the National Science Foundation for making this project possible and Rev. Badri Bajracharya, 'Living National Treasure' of Nepal.

## FEELING IS SEEING

STEVEN SCHKOLNE, The Crystal Method, 2003: This installation demonstrates the concept of sense through touch in molecular manipulation using the atomic force microscope (AFM). Based on tactility, the AFM allows molecules and atoms to be explored through their softness and hardness, and in some instances through unraveling molecular chains.

As the microscope probes, scientists use the recorded data to create visual images of the molecular surfaces. In this installation, visitors can experience both the visual and the tactile aspects of the instrument through a unique interface that allows them to explore -to the limits of the technology- magnification as well as molecular manipulation. Through a tactile interface, the visitor feels resistance and vibrations and becomes immersed in this experience of the nanoworld.

REV. BADRI RATNA BAJRACHARYA, 'Living National Treasure' of Nepal.



## FEEL SEATING SYSTEM

S2ADESIGN, Tel Aviv, 2002: A belief that the body's position is a mirror of the soul lies behind the Feel Seating System, which can change its form according to the emotional state of the body. The Feel System can create many different positions with one object; the shape is inspired by molecular structures, the basic form for all objects in the universe. It is made of 120 poly-urethane balls with rubber bands and plastic connectors.

Some activities are quite relaxing.



# AND EVENTS

## TEEN

nano@nite was an event for teens exclusively (13-17) featuring live performances and special guests including Project Blowed, Medusa, Emcee Brother J, Culture Shock, The BEAT 100.3 Street Team, DJ. Dense, deejay Raphael Woods, artists Gabe Larsen and Eder Cetina. Hip-hop and breakdance performances, spoken word, deejays, art making, and experiencing the nano installation.

April 24



## THE DARK SIDE OF THE CELL

ANNE NIEMETZ AND ANDREW PELLING: The dark side of the cell is an audio-visual event treating one of the most interesting recent discoveries in nano-biotechnology: CELLULAR SOUNDS. For a long time musicians have been inspired by microscopic life-forms and the fascinating structures of the smallest building blocks of the universe, but not until now have we been able to listen to the sound of living cells. Much mystery is brought forth by the discovery of cellular sound, and few answers can be given.

Professor James Gimzewski and Andrew Pelling at the UCLA Department of Chemistry first made the discovery that yeast cells oscillate at the nanoscale in 2002. Amplifying this oscillation results in a sound that lies within the human audible range. 'Sonocytology', the suggested term for this cutting edge field of study, represents a new realm of challenge and potential for scientists, artists, and in particular for musicians. The tool with which the cell sounds are extracted - the atomic force microscope (AFM) - can be regarded as a new type of musical instrument. Unlike microscopes that use optical imaging, the AFM 'touches' a cell with its small tip, comparable to a record needle 'feeling' the bumps in a groove on a record. With this interface, the AFM 'feels' oscillations taking place at the membrane of a cell. These electrical signals can then be amplified and distributed by speakers. Manipulating the cell with chemicals will result in a change of oscillation. Isopropanol (rubbing alcohol) for example, will change



a 'singing cell' into a 'screaming cell'. And a chemical such as sodium azide will kill the cell, causing the emitted frequency to die away, leaving only noise.

The dark side of the cell is the first composition ever to utilize cell sonics. The staging of the 'musical cells' takes place in a darkened, acoustically immersive space, enhanced with a number of sculptural objects, onto which microscopic imagery of the sonic cells and their cellular sonograms are projected. The construction of the sculptural elements is inspired by the inner architecture of cells.

This project is the collaborative effort of the media artist Anne Niemetz, and the nano-scientist Andrew Pelling, who teamed up to combine their research and interests in nano-bio-technology, sound and installation design. Niemetz and Pelling first met to work together on the sound design and setup for NANO, an interdisciplinary exhibition about nanotechnology at the Los Angeles County Museum of Art, also the space in which The dark side of the cell concert was premiered. **June 2**

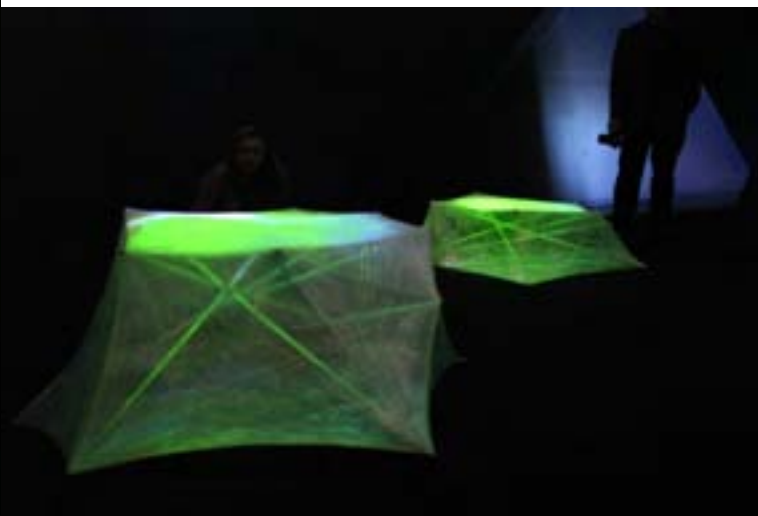

AND  
EVENTS



FASHION

ROSE BRANTLEY, director of the fashion school put together Victoria Vesna and ISABEL TOLEDO, fashion designer from New York to come up with a collaborative project using the theme and aesthetic of nano. Victoria and Jim Gimzewski gave a talk to the students to help inspire them. Jim introduced the students to the concepts of molecular manipulation and Victoria discussed the forms that appear in nature and proposed using all white. Isabel Toledo mentored the OTIS STUDENTS who created eleven dresses and Victoria worked with her team and graduate student LAURA ANDRADE on the projections. The creations premiered at the Otis Scholarship Benefit Gala at the Beverly Hilton hotel. **May 1**

TOP RIGHT: Ruben and Isabel Toledo with Victoria Vesna.



## DANCE

ANY/NANO/BODY: a dance performance event was an innovative in its choreography and site-specific improvisation.

Choreographers MARIANNE KIM and NORAH ZUNIGA SHAW worked with master performers Harmony Bench, Peter Carpenter, Monica Gillette, Marianne Kim, Kristen Smiarowski, and Cheng-Chieh Yu to discover the nano science of our bodies and put it into motion. Victoria Vesna and her team create a media swarm around them and the dancers will be clothed in futuristic costumes by New York fashion diva ISABEL TOLEDO and students from the OTIS SCHOOL OF DESIGN. June 20



# PEOPLE

This exhibition was produced by LACMALab, the research and development unit of the Los Angeles County Museum of Art, and the University of California, Los Angeles.

The exhibition was made possible in part by Union Bank of California, Bert Levy, the David Bermant Foundation and Veeco Instruments. In-kind support was provided by IBM, Canon U.S.A., Inc., and Epson.

UCLA units supporting this exhibition include the Chemistry and Biochemistry Department, the Design|Media Arts Department, Office of Research, Pico Lab, School of the Arts and Architecture, SINAPSE, and Technology Sandbox.

Additional support was provided by UC Digital Arts Research Network and UC Discovery.

LACMALab is supported in part by the Caryll Mudd Sprague Endowment for the Education of Children.

Exhibitions in the Boone Children's Gallery are made possible in part by the MaryLou and George Boone Children's Gallery Endowment Fund.

Installations conceived and developed by Victoria Vesna Chair, Design|Media Arts Department, UCLA and James K. Gimzewski Chemistry and Biochemistry Department, UCLA.

Text component on the walls developed by N. Katherine Hayles Hillis Professor of Literature, English Department, UCLA.

Architecture developed by Johnston Marklee & Associates, Los Angeles.

catalogue design: Willem Henri Lucas visiting professor Design|Media Arts Department, Bonnie Begusch student D|MA Department.

